

System drawings shown in this bulletin are for illustration purposes only. Refrigeration systems should only be serviced by a qualified technician. Always observe proper safety procedures when servicing a refrigeration system. For more information see the latest revision of Phillips Safety Bulletin SGRV.

GENERAL INFORMATION

Pressure Rating: 300 psig (21 bar, gauge)

Temperature Rating: -20°F to 240°F
(-29°C to 116°C)

The 700X Series flanged in-line piston-type check valves are spring closing and can be supplied with a 2, 5, 10, 20, 35, 50, 60, 70 and 90 pound differential spring to suit your application. They have a manual lifting stem and replaceable Teflon seat disc.

The 700X Series check valves prevent reverse flow of refrigerant in suction, hot gas and liquid lines. These valves are applicable for reciprocating compressor discharge line service, refrigerant pump discharge and

suction line service and can be applied as a hot defrost relief valve. These valves can also be applied as the outlet check valve for various liquid transfer systems.

Valves in this series include the 700JRX, 700X, 700AX and 700BX. If the valve is applied to a halocarbon system, the suffix "F" is applied to the valve designation (example: 700JRXF).

The 700X Series check valve is normally closed, spring actuated. When the refrigerant mass flow is sufficient to create a pressure drop across the valve to overcome the force of its closing spring, the disc is forced away from its seat, permitting flow. As the mass flow decreases, the pressure drop across the disc will decrease and the disc will be forced back against its seat by the closing spring.

TROUBLESHOOTING

Problem: Check valve does not open

- A) Piston may be jammed in the bore of the valve body in a closed position.

Solution: If the piston has considerable wear or is rusted, change the piston and install a new bonnet gasket.

- B) Spring may be broken and causing the jamming of the piston in a closed position.

Solution: Secure a new spring for the pressure drop required and install a new bonnet gasket.

- C) The Teflon seat disc may be holding on the valve body port seat bead, holding the valve in a closed position.

Solution: Install a new seat disc and bonnet gasket.

- D) The check valve may be installed in backwards.

Solution: Flow is in the direction of the nameplate on the bonnet, upwards through the check valve port, past the Teflon seat disc of the piston, and out through the downstream side of the valve.

Problem: Check valve does not close

- A) Piston may be jammed in the bore of the valve body, causing the valve be in an open position.

Solution: If the piston has considerable wear or is rusted, change the piston and bonnet gasket.

- B) Spring may be broken, causing a loss of closing force, and may cause the jamming of the piston in an open position.

Solution: Secure a new spring for the pressure drop required and install a new bonnet gasket.

- C) The Teflon seat disc may be heavily impressed with the seat configuration allowing the piston to bear against the valve body, or the Teflon seat disc is broken or missing.

Solution: Install a new seat disc and bonnet gasket.

- D) Debris may be on top of the seat or driven into the Teflon seat disc, holding the valve in an open position.

Solution: Clean the seat disc and seat thoroughly. Replace if necessary.

REPLACEMENT PARTS

When contacting Phillips for replacement parts, have the complete valve model and serial number (shown on the valve nameplate) available to ensure you receive the correct components. For example: "700AXHF2-OR" is a complete valve model, and "990123" or "E-12345" are complete serial numbers.

Table 1: Replacement Parts

Description	700JRX	700X	700AX	700BX
Bonnet Screw	577 (4)	577 (4)	718 (4)	1459 (4)
Bonnet	700-2	700-2	700-2A	700-2B
Bonnet Gasket *	710	710	710A	710B
Spring	See Table 2			
Piston	700-4JRX	700-4X	700-4AX	700-4BX
Valve Body	700JRF-VB	700F-VB	700AF-VB	700BXF-VB
Flange Gasket *	506 (2)	725N (2)	73 (2)	326Y (2)
Seat Disc *	703	700-3X	700-3AX	700-3BX
Flush Plug	700-7JR	700-7	700-7AX	700-7BX
Manual Stem	711X	711X	711AXT	711B
Packing Ring	775	775	775	777BN
Gland	8	8	8	8B
Seal Cap (not shown)	714	714	714	714B
Seal Cap Gasket (not shown)	720	720	720	720B
Flange Bolt	726B (2)	726 (2)	23 (8)	24A (8)
Flange Nut	58 (2)	58 (2)	58 (8)	59 (8)
*Spare Parts Kit (Includes Items 3, 7, 8)	K700JR	K700X	K700AX	K700BX

Table 2: Springs

PSI Differential	Spring Part Numbers			
	700JRX	700X	700A & AX	700B & BX
2	705-1L	705-5L	705A-2L	705B-3L
5	705-5L	705-10L	705A-10L	705B-10L
10	705-10L	705-20L	705A-20L	705B-30L
20	705-20L	705-35L	705A-30L	705B-60L
35	705-35L	705-60L	705A-60L	-
50	705-50L	705-90L	-	-
60	705-60L	-	-	-
70	705-70L	705-130L	705A-110L	-
90	705-90L	-	705A-165L	-

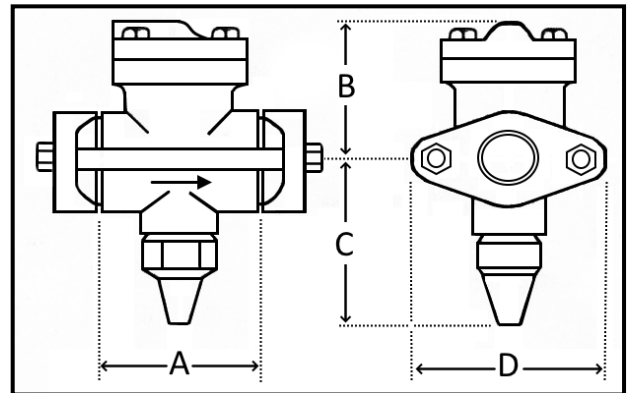
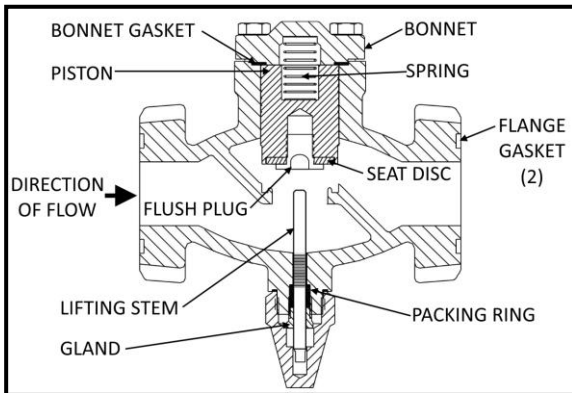

Table 3: Dimensions (in.)

Valve Number	A	B	C	D	Orifice Size	Flanges			Weight (lbs.)	
						Type	Flange Sizes	Bolts		
								Number		Size
700JRX	3-1/2	3-3/4	4-1/2	4-1/8	3/4	Oval	1/2, 3/4, 1 (FPT, SW) 1-1/8, 1-3/8 (ODC)	2	1/2	14
700X	4	3-3/4	4-1/2	5	1	Oval	1, 1-1/4 (FPT, SW, WN) 1-5/8 (ODC)	2	5/8	20
700AX	9	4-3/4	5-1/2	4-3/4	1-1/2	Square	1-1/2, 2 (FPT, SW, WN) 2-1/8 (ODC)	4	5/8	40
700BX	10	6-1/4	7	6	2-1/4	Square	3 (SW, WN) 3-1/8 (ODC)	4	3/4	75

H.A. Phillips & Co.
 770 Enterprise Avenue
 DeKalb, IL 60115 USA
 Phone: (630) 377-0050

