

# Phillips®

## REFRIGERATION

VALVES • VESSELS • SYSTEMS • CONTROLS



770 Enterprise Avenue  
DeKalb, IL 60115



[info@haphillips.com](mailto:info@haphillips.com)



630.377.0050

PHILLIPS REFRIGERATION

VESSELS & SYSTEMS

## Capabilities

### Facility

In 2011 Phillips built and moved into a brand new facility located in DeKalb, IL. Due to extremely high demand, an addition was built in 2012, which brings our total manufacturing space to 25,000 square feet. Phillips continues to grow to meet customer demand.

### Welding Quality

H.A. Phillips & Co.'s welding fabrication processes are second-to-none in industrial refrigeration. All of our welders are ASME certified and have completed rigorous training. We maintain several sub-arc welding stations, which allow for greater production efficiency and consistency. Our welders are skilled in MIG, TIG, stick, flux-core and sub-arc welding processes. We are equally proficient in welding carbon steel as well as stainless steel. In February 2013 we installed a new CNC controlled pipe cutting machine for cutting nozzle holes into shells.

### ASME Certification

H.A. Phillips & Co. holds an ASME 'U' stamp and a National Board 'R' stamp. Our Quality Management System and welders are certified in accordance with the ASME Code Section VIII, Division 1. Every welder certification test is evaluated in accordance with Section IX of the ASME code by an outside authority. Furthermore, all ASME Code work is inspected by an independent agency prior to applying the U-stamp of approval.

### ISO 9001 Certification

H.A. Phillips & Co. has been ISO certified since 2000. We are currently certified to ISO 9001:2024. The organization of H.A. Phillips & Co. is committed to being a preeminent global manufacturer of high quality welded, machined, electrical and electronically controlled products.

### Pump Recirculation Packages

Phillips mechanical pump recirculation packages are available up to 144" diameter. Each pump recirculation package is custom designed and packages come standard with Phillips check valves and Danfoss hand valves. While Phillips and Danfoss valve options provide the most economical design, we can package with any valve brand per the customer's preference. We also package with customer's choice of Nikkiso, Teikoku or Cornell pumps.

### Plate & Frame Chiller Packages

Factory-packaged plate and frame heat exchangers with surge drums, columns, oil pots and liquid makeup valve trains are available. We can provide the complete skid-mounted turnkey package with customer's choice of plate heat exchangers, or the customer can supply the heat exchanger and Phillips can provide the packaging. Either option reduces expensive field labor and increases quality by using our highly qualified fitters in a factory environment.

### Gas Recirculation Systems

As a pioneer in gas-driven recirculation systems, Phillips continues to provide engineering assistance and vessel fabrication for these energy-and maintenance-efficient overfeed systems. Phillips engineers can size the CPR, Gas Recirculating System and High Side Control to meet your recirculation needs.

### Engineering

Our engineering staff can help you custom-design the vessel or packaged system for your application in terms of storage capacity, liquid-vapor separation, pressure rating, nozzle sizing and mounting requirements.

### CAD

We utilize the latest SolidWorks modeling software and can provide 3D models of vessels and systems upon request. Utilizing DriveWorks software, our Engineers have developed a rapid quotation system integrated with SolidWorks that allows for the fastest quote turnaround in the industry and quick drawing turnaround for customer approval.

### Valve Trains

H.A. Phillips can assist you by sub-assembling valve trains to ensure correct and fast installation at the job site. Phillips engineers will help you with your selection, whether you prefer solenoid, motorized valve, or Pulse-Width Modulated control. Danfoss ICF valve stations are also available from Phillips.

### Level Columns

Let Phillips provide you with the level column for your vessel. We can supply you with 2", 2-1/2" and 3" diameter columns with Level Eye® sight glasses available with clear or reflex lenses, with or without frost shields, with drain and/or probe connections and float switch couplings. Options include factory mounted float switches, drain valves and valved and/or flanged vessel connections. Columns are available with rapid turnaround.

### Danfoss Products

H.A. Phillips has been a reseller of Danfoss Industrial Refrigeration products for over 30 years. Our large inventory allows us to process orders quickly from a single item to a complete project. Danfoss valves come as standard on all our packaged systems.

**Standard Features**

- ASME Certification: All pressure vessels are designed, fabricated, tested, inspected and stamped in accordance with ASME Section VIII, Division 1 Pressure Vessel Code and are National Board registered.
- Maximum Allowable Working Pressure (MAWP): 250 PSI low side vessels, 300 PSI high side vessels from -20°F to +450°F. Dual stamped to -60°F at reduced pressure (unless otherwise noted). Other MAWPs and lower temperatures are available.
- Heads: 2:1 Semi-elliptical SA 516-70N carbon steel
- Shells: 24" diameter and smaller are SA 106 S/B or SA 53 E/B or S/B pipe. 30" diameter and larger are rolled SA 516-70 carbon steel plate.
- Lifting lugs are standard on all vessels 30" in diameter and larger
- Nozzle Materials: ASTM A-53 B and ASTM A-106B. ASTM A-333 Gr. 6 available where necessary.
- Nozzle Thickness: 2" and smaller, Schedule 80. Larger than 2" are Schedule 40.
- Fittings: Class 3000
- 1 coat primer and 4-6 mils of engineered epoxy top coat

**Available Options**

- Stainless Steel construction
- Radiography (X-Ray)
- Nitrogen Charge
- Abrasive blasting (SSPC-SP 6)
- Post Weld Heat Treat (PWHT)
- Special Paint/Color

**Table 2 - Separation Capacities of Separation Vessels, Tons of Refrigeration\***

| Nominal Diameter | Vertical Vessel |       |      |      | Horizontal Vessel† |       |      |      | Horizontal, Split Flow Baffle†° |       |      |      |
|------------------|-----------------|-------|------|------|--------------------|-------|------|------|---------------------------------|-------|------|------|
|                  | -50°F           | -20°F | 0°F  | 30°F | -50°F              | -20°F | 0°F  | 30°F | -50°F                           | -20°F | 0°F  | 30°F |
| 8                | 7.8             | 11.8  | 15.0 | 21   | 3.8                | 5.9   | 7.5  | 11   | 6                               | 9.2   | 12.5 | 18.2 |
| 10               | 12.3            | 18.7  | 24.0 | 34   | 6.2                | 9.4   | 12.0 | 17   | 10.1                            | 15.0  | 20.6 | 29.0 |
| 12               | 17.6            | 27    | 34   | 48   | 8.8                | 14.0  | 17   | 24   | 13                              | 19.0  | 26.0 | 37   |
| 14               | 22              | 33    | 42   | 58   | 11.4               | 17    | 21   | 29   | 18.5                            | 28.0  | 37   | 52   |
| 16               | 28              | 43    | 55   | 77   | 14                 | 22    | 28   | 39   | 24                              | 37    | 48   | 68   |
| 18               | 36              | 55    | 70   | 98   | 18                 | 28    | 35   | 49   | 31.5                            | 48    | 63   | 88   |
| 20               | 44              | 68    | 87   | 121  | 22                 | 34    | 44   | 61   | 39                              | 59    | 77   | 108  |
| 24               | 63              | 97    | 124  | 173  | 31                 | 49    | 62   | 87   | 56                              | 85    | 110  | 154  |
| 30               | 100             | 153   | 196  | 273  | 50                 | 77    | 98   | 137  | 89                              | 136   | 175  | 245  |
| 36               | 145             | 222   | 284  | 397  | 72                 | 111   | 142  | 199  | 130                             | 198   | 255  | 356  |
| 42               | 199             | 304   | 389  | 543  | 99                 | 152   | 195  | 272  | 178                             | 272   | 350  | 489  |
| 48               | 261             | 399   | 511  | 713  | 130                | 200   | 256  | 357  | 234                             | 358   | 459  | 642  |
| 54               | 329             | 501   | 643  | 897  | 164                | 251   | 322  | 449  | 295                             | 450   | 579  | 808  |
| 60               | 407             | 621   | 797  | 1111 | 203                | 311   | 399  | 556  | 366                             | 559   | 717  | 1001 |
| 72               | 586             | 892   | 1146 | 1598 | 293                | 446   | 573  | 799  | 526                             | 804   | 1032 | 1440 |
| 84               | 797             | 1222  | 1567 | 2185 | 398                | 611   | 784  | 1093 | 716                             | 1094  | 1404 | 1959 |
| 96               | 1045            | 1594  | 2044 | 2850 | 522                | 797   | 1022 | 1425 | 940                             | 1436  | 1843 | 2570 |
| 108              | 1322            | 2015  | 2583 | 3603 | 661                | 1008  | 1292 | 1802 | 1189                            | 1816  | 2330 | 3250 |
| 120              | 1630            | 2485  | 3186 | 4444 | 815                | 1243  | 1593 | 2222 | 1466                            | 2240  | 2874 | 4008 |
| 144              | 2345            | 3586  | 4594 | 6413 | 1172               | 1793  | 2297 | 3207 | 2109                            | 3223  | 4133 | 5764 |

**Table 1 - Vessel Volumes**

| Nominal Diameter | Single 2:1 Head, ft³ | Shell ft³/ft |
|------------------|----------------------|--------------|
| 6                | 0.043                | 0.205        |
| 8                | 0.086                | 0.360        |
| 10               | 0.177                | 0.573        |
| 12               | 0.276                | 0.818        |
| 14               | 0.352                | 0.994        |
| 16               | 0.500                | 1.31         |
| 18               | 0.684                | 1.67         |
| 20               | 0.907                | 2.07         |
| 24               | 1.44                 | 2.95         |
| 30               | 2.67                 | 4.67         |
| 36               | 4.45                 | 6.78         |
| 42               | 6.86                 | 9.28         |
| 48               | 10.0                 | 12.2         |
| 54               | 13.8                 | 15.3         |
| 60               | 18.7                 | 19.0         |
| 72               | 31.4                 | 27.3         |
| 84               | 49.1                 | 37.3         |
| 96               | 72.0                 | 48.7         |
| 108              | 101                  | 61.6         |
| 120              | 137                  | 75.9         |
| 144              | 234                  | 110          |

\*Assumes thickness required for 250PSIG rating

\*Assumes 96°F liquid feed

†Horizontal capacity assumes max liquid level, including surge, at midpoint of vessel

°Split flow sizing is for suction accumulators and split flow surge drums. See page 34 for horizontal recirculator sizing.

**Table 3 - Various Nozzle Capacities, Tons of Refrigeration**

| IPS (in) | Liquid Leg* | Wet Suction Nozzle |       |      |      | Dry Suction Nozzle |       |      |      |
|----------|-------------|--------------------|-------|------|------|--------------------|-------|------|------|
|          |             | -50                | -20°F | 0°F  | 30°F | -50                | -20°F | 0°F  | 30°F |
| ¾        | 1           | 0.21               | 0.37  | 0.49 | 0.68 | 0.54               | 1.2   | 1.9  | 4.0  |
| 1        | 2           | 0.4                | 0.76  | 1    | 1.4  | 1                  | 2.1   | 3.5  | 7.4  |
| 1-¼      | 4           | 0.9                | 1.6   | 2.1  | 2.9  | 2                  | 4.2   | 7.0  | 15   |
| 1-½      | 6           | 1.4                | 2.4   | 3.2  | 4.5  | 2.9                | 6.2   | 10.1 | 21   |
| 2        | 11          | 3.4                | 5.8   | 7.7  | 11   | 5.5                | 12    | 19   | 41   |
| 2½       | 18          | 5.9                | 9.7   | 13   | 17   | 8.7                | 18    | 30   | 64   |
| 3        | 30          | 9.9                | 16    | 21   | 30   | 15                 | 31    | 50   | 106  |
| 4        | 60          | 21                 | 35    | 45   | 63   | 29                 | 63    | 105  | 229  |
| 5        | 105         | 38                 | 63    | 82   | 115  | 51                 | 108   | 180  | 384  |
| 6        | 160         | 62                 | 103   | 134  | 187  | 80                 | 168   | 275  | 578  |
| 8        | 330         | 127                | 211   | 276  | 386  | 150                | 287   | 443  | 846  |
| 10       | 600         | 266                | 405   | 535  | 815  | 349                | 531   | 703  | 1070 |
| 12       | 925         | 416                | 633   | 837  | 1274 | 510                | 776   | 1027 | 1563 |
| 14       | 1150        | 531                | 808   | 1069 | 1628 | 628                | 956   | 1264 | 1924 |
| 16       | 1750        | 752                | 1144  | 1514 | 2303 | 843                | 1283  | 1697 | 2583 |
| 18       | 2400        | 998                | 1518  | 2009 | 3058 | 1097               | 1670  | 2210 | 3363 |
| 20       | 3186        | 1279               | 1946  | 2575 | 3919 | 1373               | 2090  | 2766 | 4209 |
| 24       | 5201        | 1943               | 2957  | 3912 | 5954 | 2039               | 3103  | 4106 | 6249 |

\* Liquid line capacity doubles if integral oil pot larger than the liquid leg is used.

# Vertical High Pressure Receiver

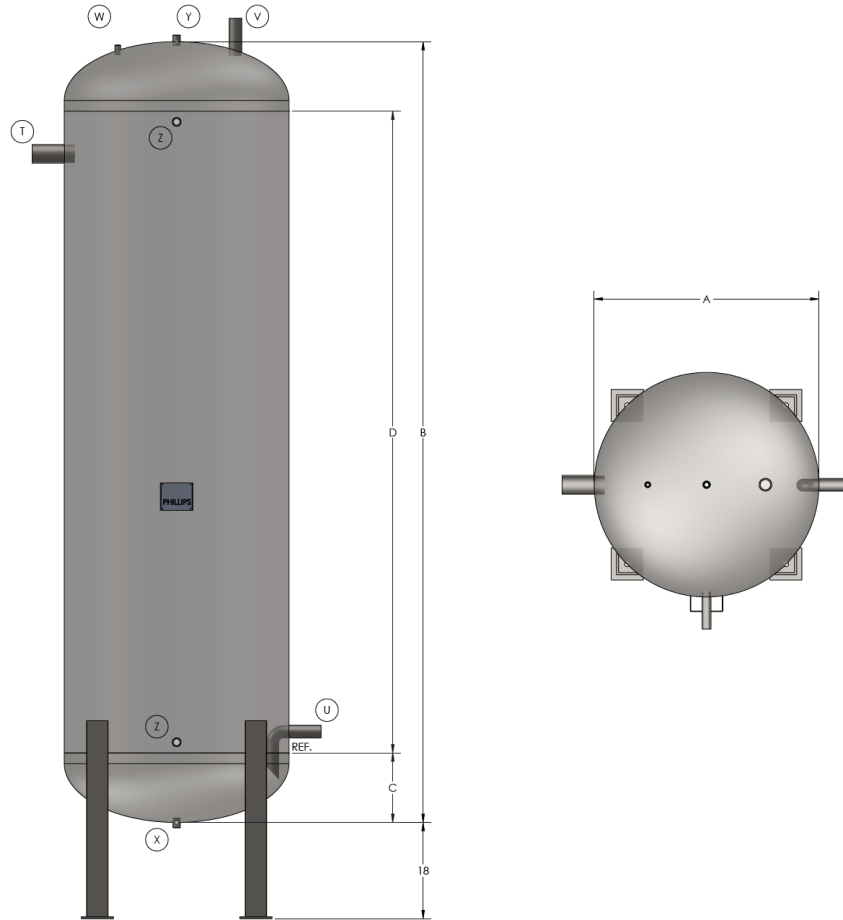

| Model No.  | A<br>Dia. | B<br>OAH | C<br>Head | D<br>Shell | T<br>Liquid Inlet | U<br>Liquid Outlet | V<br>Equal | W<br>Purge | X<br>Drain | Y<br>Relief | Z<br>Column (Qty 2) | Est. Shipping Wt. (lbs.) | R-717 Capacity (lbs.)* |
|------------|-----------|----------|-----------|------------|-------------------|--------------------|------------|------------|------------|-------------|---------------------|--------------------------|------------------------|
| HPRV-20111 | 20        | 111      | 7½        | 96         | 1¼                | ¾                  | ¾          | ¾          | ¾          | ¾           | 1¼                  | 590                      | 539                    |
| HPRV-20135 | 20        | 135      | 7½        | 120        | 1¼                | 1                  | 1          | ¾          | ¾          | ¾           | 1¼                  | 690                      | 660                    |
| HPRV-20207 | 20        | 207      | 7½        | 192        | 1½                | 1                  | 1          | ¾          | ¾          | ¾           | 1¼                  | 1020                     | 1025                   |
| HPRV-24137 | 24        | 137      | 8½        | 120        | 1½                | 1¼                 | 1¼         | ¾          | ¾          | ¾           | 1¼                  | 1210                     | 950                    |
| HPRV-24209 | 24        | 209      | 8½        | 192        | 2                 | 1½                 | 1¼         | ¾          | ¾          | ¾           | 1¼                  | 1780                     | 1469                   |
| HPRV-30140 | 30        | 140      | 10        | 120        | 2½                | 1½                 | 1½         | ¾          | ¾          | ¾           | 1¼                  | 1590                     | 1527                   |
| HPRV-30212 | 30        | 212      | 10        | 192        | 2½                | 1½                 | 2          | ¾          | ¾          | ¾           | 1¼                  | 2310                     | 2349                   |
| HPRV-36143 | 36        | 143      | 11½       | 120        | 2½                | 1½                 | 1½         | ¾          | ¾          | ¾           | 1¼                  | 1940                     | 2250                   |
| HPRV-36215 | 36        | 215      | 11½       | 192        | 3                 | 2                  | 2          | ¾          | ¾          | ¾           | 1¼                  | 2810                     | 3443                   |
| HPRV-42146 | 42        | 146      | 13        | 120        | 3                 | 2                  | 2          | ¾          | ¾          | ¾           | 1¼                  | 2360                     | 3125                   |
| HPRV-42218 | 42        | 218      | 13        | 192        | 3                 | 2                  | 2          | ¾          | ¾          | ¾           | 1¼                  | 3370                     | 4758                   |
| HPRV-48149 | 48        | 149      | 14½       | 120        | 3                 | 2                  | 2          | ¾          | 1          | ¾           | 1¼                  | 2750                     | 4166                   |
| HPRV-48221 | 48        | 221      | 14½       | 192        | 3                 | 2                  | 2          | ¾          | 1          | ¾           | 1¼                  | 3910                     | 6313                   |
| HPRV-54152 | 54        | 152      | 16        | 120        | 3                 | 2                  | 2          | ¾          | 1          | ¾           | 1¼                  | 4140                     | 5298                   |
| HPRV-54224 | 54        | 224      | 16        | 192        | 4                 | 2½                 | 2½         | ¾          | 1          | ¾           | 1¼                  | 5880                     | 7991                   |
| HPRV-60155 | 60        | 155      | 17½       | 120        | 4                 | 2½                 | 2½         | ¾          | 1          | ¾           | 1¼                  | 4750                     | 6671                   |
| HPRV-60227 | 60        | 227      | 17½       | 192        | 4                 | 3                  | 3          | ¾          | 1          | ¾           | 1¼                  | 6680                     | 10015                  |
| HPRV-72161 | 72        | 161      | 20½       | 120        | 4                 | 3                  | 3          | ¾          | 1          | ¾           | 1¼                  | 7550                     | 9851                   |
| HPRV-72233 | 72        | 233      | 20½       | 192        | 4                 | 3                  | 3          | ¾          | 1          | 1           | 1¼                  | 10440                    | 14656                  |
| HPRV-84167 | 84        | 167      | 23½       | 120        | 4                 | 3                  | 3          | ¾          | 1          | ¾           | 1¼                  | 9250                     | 13823                  |
| HPRV-84239 | 84        | 239      | 23½       | 192        | 5                 | 4                  | 4          | ¾          | 1          | 1           | 1¼                  | 12630                    | 20389                  |
| HPRV-84287 | 84        | 287      | 23½       | 240        | 6                 | 5                  | 5          | ¾          | 1          | 1¼          | 1¼                  | 14890                    | 24765                  |
| HPRV-96173 | 96        | 173      | 26½       | 120        | 6                 | 5                  | 5          | ¾          | 1          | 1           | 1¼                  | 13420                    | 18511                  |
| HPRV-96245 | 96        | 245      | 26½       | 192        | 8                 | 5                  | 5          | ¾          | 1          | 1¼          | 1¼                  | 18050                    | 27083                  |
| HPRV-96293 | 96        | 293      | 26½       | 240        | 8                 | 5                  | 5          | ¾          | 1          | 1¼          | 1¼                  | 21130                    | 32798                  |

\*Assuming 80% vessel capacity at 95°F

All vessels are custom-built to customer specifications. Vessel dimensions and nozzle sizes in tables are suggestions for nominal conditions.

# Horizontal High Pressure Receiver

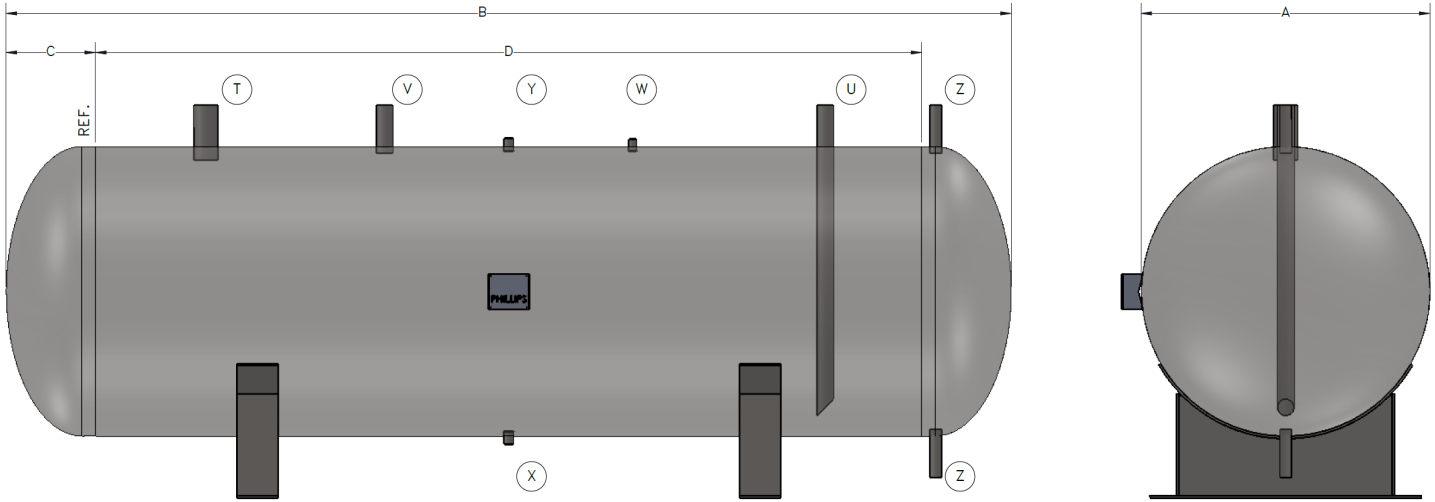

| Model No.  | A<br>Dia. | B<br>OAL | C<br>Head | D<br>Shell | T<br>Liquid Inlet | U<br>Liquid Outlet | V<br>Equal | W<br>Purge | X<br>Drain | Y<br>Relief | Z<br>Column (Qty 2) | Est. Shipping Wt. (lbs.) | R-717 Capacity (lbs.)* |
|------------|-----------|----------|-----------|------------|-------------------|--------------------|------------|------------|------------|-------------|---------------------|--------------------------|------------------------|
| HPRH-20111 | 20        | 111      | 7½        | 96         | 1¼                | ¾                  | ¾          | ¾          | ¾          | ¾           | 1¼                  | 600                      | 539                    |
| HPRH-20135 | 20        | 135      | 7½        | 120        | 1¼                | 1                  | 1          | ¾          | ¾          | ¾           | 1¼                  | 700                      | 660                    |
| HPRH-24113 | 24        | 113      | 8½        | 96         | 1½                | 1¼                 | 1¼         | ¾          | ¾          | ¾           | 1¼                  | 1050                     | 777                    |
| HPRH-24137 | 24        | 137      | 8½        | 120        | 1½                | 1¼                 | 1¼         | ¾          | ¾          | ¾           | 1¼                  | 1240                     | 950                    |
| HPRH-30116 | 30        | 116      | 10        | 96         | 2                 | 1¼                 | 1¼         | ¾          | ¾          | ¾           | 1¼                  | 1380                     | 1253                   |
| HPRH-30140 | 30        | 140      | 10        | 120        | 2½                | 1½                 | 1½         | ¾          | ¾          | ¾           | 1¼                  | 1630                     | 1527                   |
| HPRH-36119 | 36        | 119      | 11½       | 96         | 2                 | 1½                 | 1½         | ¾          | ¾          | ¾           | 1¼                  | 1730                     | 1852                   |
| HPRH-36143 | 36        | 143      | 11½       | 120        | 2½                | 1½                 | 1½         | ¾          | ¾          | ¾           | 1¼                  | 2020                     | 2250                   |
| HPRH-42122 | 42        | 122      | 13        | 96         | 2½                | 1½                 | 1½         | ¾          | ¾          | ¾           | 1¼                  | 2120                     | 2580                   |
| HPRH-42146 | 42        | 146      | 13        | 120        | 3                 | 2                  | 2          | ¾          | ¾          | ¾           | 1¼                  | 2460                     | 3125                   |
| HPRH-48149 | 48        | 149      | 14½       | 120        | 3                 | 2                  | 2          | ¾          | 1          | ¾           | 1¼                  | 2890                     | 4166                   |
| HPRH-48221 | 48        | 221      | 14½       | 192        | 3                 | 2                  | 2          | ¾          | 1          | ¾           | 1¼                  | 4040                     | 6313                   |
| HPRH-48269 | 48        | 269      | 14½       | 240        | 4                 | 2½                 | 2½         | ¾          | 1          | ¾           | 1¼                  | 4820                     | 7745                   |
| HPRH-54152 | 54        | 152      | 16        | 120        | 3                 | 2                  | 2          | ¾          | 1          | ¾           | 1¼                  | 4280                     | 5298                   |
| HPRH-54224 | 54        | 224      | 16        | 192        | 4                 | 3                  | 3          | ¾          | 1          | ¾           | 1¼                  | 6030                     | 7991                   |
| HPRH-54272 | 54        | 272      | 16        | 240        | 4                 | 3                  | 3          | ¾          | 1          | ¾           | 1¼                  | 7180                     | 9786                   |
| HPRH-60155 | 60        | 155      | 17½       | 120        | 4                 | 2½                 | 2½         | ¾          | 1          | ¾           | 1¼                  | 4930                     | 6671                   |
| HPRH-60227 | 60        | 227      | 17½       | 192        | 4                 | 3                  | 3          | ¾          | 1          | ¾           | 1¼                  | 6860                     | 10015                  |
| HPRH-60275 | 60        | 275      | 17½       | 240        | 4                 | 3                  | 3          | ¾          | 1          | 1           | 1¼                  | 8150                     | 12245                  |
| HPRH-72233 | 72        | 233      | 20½       | 192        | 5                 | 3                  | 3          | ¾          | 1          | 1           | 1¼                  | 10490                    | 14656                  |
| HPRH-72281 | 72        | 281      | 20½       | 240        | 5                 | 4                  | 4          | ¾          | 1          | 1           | 1¼                  | 12440                    | 17860                  |
| HPRH-84239 | 84        | 239      | 23½       | 192        | 5                 | 4                  | 4          | ¾          | 1          | 1           | 1¼                  | 12770                    | 20389                  |
| HPRH-84287 | 84        | 287      | 23½       | 240        | 6                 | 4                  | 4          | ¾          | 1          | 1¼          | 1¼                  | 15020                    | 24765                  |
| HPRH-96245 | 96        | 245      | 26½       | 192        | 6                 | 4                  | 4          | ¾          | 1          | 1¼          | 1¼                  | 18140                    | 27083                  |
| HPRH-96293 | 96        | 293      | 26½       | 240        | 8                 | 4                  | 4          | ¾          | 1          | 1¼          | 1¼                  | 21220                    | 32798                  |

\*Assuming 80% vessel capacity at 95°F

All vessels are custom-built to customer specifications. Vessel dimensions and nozzle sizes in tables are suggestions for nominal conditions.

Vertical High Pressure Thermo-Syphon Receiver

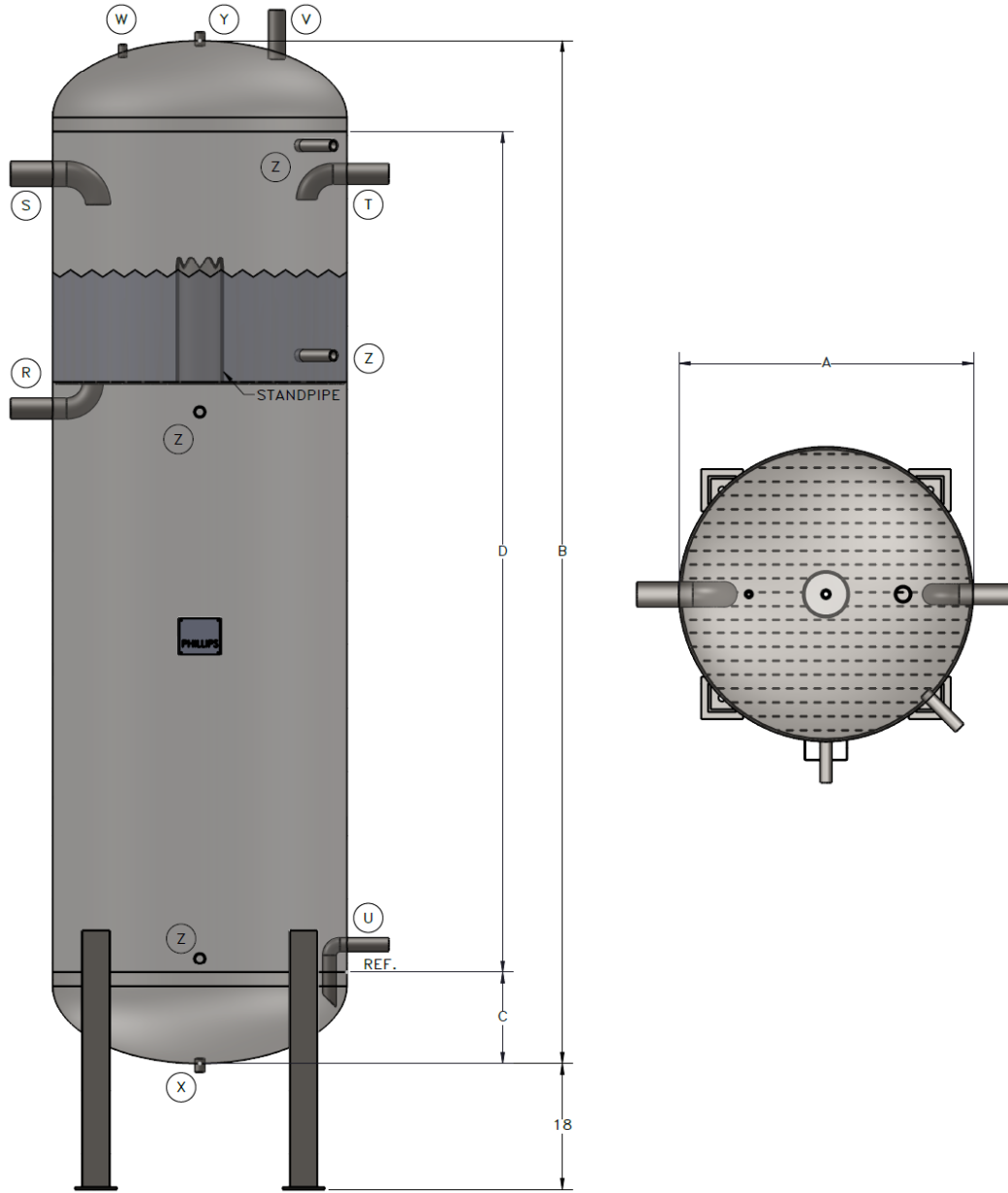

| Model No.    | A    | B   | C    | D     | R             | S               | T          | U            | V             | W     | X     | Y     | Z      | Est. Shipping Wt. (lbs.) |       |
|--------------|------|-----|------|-------|---------------|-----------------|------------|--------------|---------------|-------|-------|-------|--------|--------------------------|-------|
|              | Dia. | OAH | Head | Shell | To Oil Cooler | From Oil Cooler | Standpipe  | Liquid Inlet | Liquid Outlet | Equal | Purge | Drain | Relief | Column (Qty 4)           |       |
| HPRTSV-20135 | 20   | 135 | 7½   | 120   | 1½            | 2               | 6"Ø x 18"  | 1¼           | ¾             | 1     | ¾     | ¾     | ¾      | 1¼                       | 750   |
| HPRTSV-24137 | 24   | 137 | 8½   | 120   | 2             | 2½              | 6"Ø x 18"  | 1½           | 1¼            | 1¼    | ¾     | ¾     | ¾      | 1¼                       | 900   |
| HPRTSV-30140 | 30   | 140 | 10   | 120   | 2             | 2½              | 6"Ø x 18"  | 2            | 1¼            | 1¼    | ¾     | ¾     | ¾      | 1¼                       | 1680  |
| HPRTSV-36143 | 36   | 143 | 11½  | 120   | 2½            | 3               | 6"Ø x 18"  | 2            | 1½            | 1½    | ¾     | ¾     | ¾      | 1¼                       | 2050  |
| HPRTSV-42146 | 42   | 146 | 13   | 120   | 2½            | 3               | 6"Ø x 18"  | 2½           | 1½            | 2     | ¾     | ¾     | ¾      | 1¼                       | 2500  |
| HPRTSV-48221 | 48   | 221 | 14½  | 192   | 3             | 4               | 6"Ø x 18"  | 3            | 2             | 2     | ¾     | 1     | ¾      | 1¼                       | 4090  |
| HPRTSV-54224 | 54   | 224 | 16   | 192   | 3             | 4               | 6"Ø x 18"  | 4            | 3             | 3     | ¾     | 1     | ¾      | 1¼                       | 6100  |
| HPRTSV-60227 | 60   | 227 | 17½  | 192   | 3             | 4               | 6"Ø x 18"  | 4            | 3             | 3     | ¾     | 1     | ¾      | 1¼                       | 6940  |
| HPRTSV-72281 | 72   | 281 | 20½  | 240   | 4             | 5               | 6"Ø x 18"  | 5            | 4             | 4     | ¾     | 1     | 1      | 1¼                       | 12750 |
| HPRTSV-84287 | 84   | 287 | 23½  | 240   | 5             | 6               | 8"Ø x 18"  | 6            | 4             | 4     | ¾     | 1     | 1¼     | 1¼                       | 18240 |
| HPRTSV-96293 | 96   | 293 | 26½  | 240   | 5             | 6               | 10"Ø x 18" | 8            | 4             | 4     | ¾     | 1     | 1¼     | 1¼                       | 21760 |

All vessels are custom-built to customer specifications. Vessel dimensions and nozzle sizes in tables are suggestions for nominal conditions.

# Horizontal High Pressure Thermo-Syphon Receiver

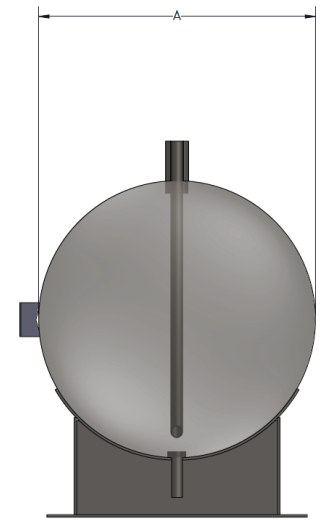
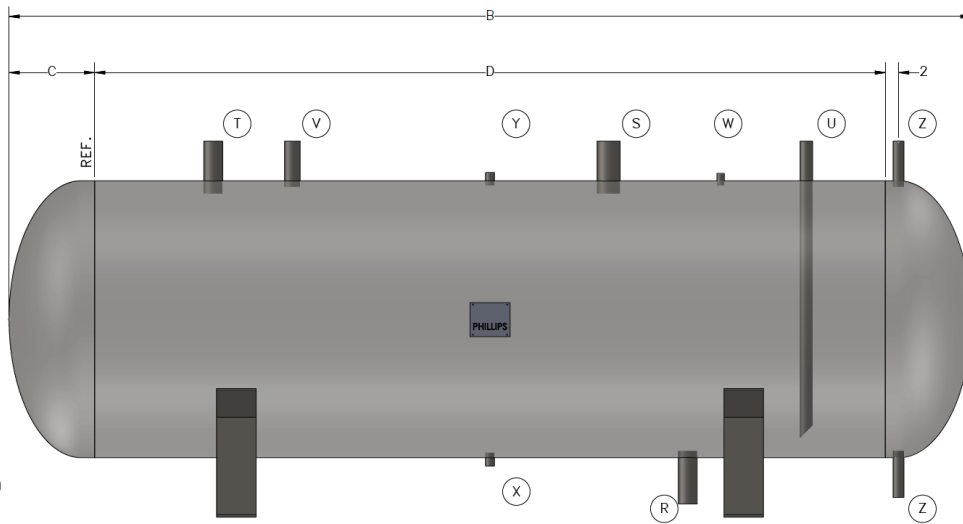

| Model No.    | A    | B   | C    | D     | R             | S               | T            | U             | V     | W     | X     | Y      | Z              | Est. Shipping Wt. (lbs.) |
|--------------|------|-----|------|-------|---------------|-----------------|--------------|---------------|-------|-------|-------|--------|----------------|--------------------------|
|              | Dia. | OAL | Head | Shell | To Oil Cooler | From Oil Cooler | Liquid Inlet | Liquid Outlet | Equal | Purge | Drain | Relief | Column (Qty 2) |                          |
| HPRTSH-20135 | 20   | 135 | 7½   | 120   | 1½            | 2               | 1¼           | ¾             | 1     | ¾     | ¾     | ¾      | 1¼             | 690                      |
| HPRTSH-24137 | 24   | 137 | 8½   | 120   | 2             | 2½              | 1½           | 1¼            | 1¼    | ¾     | ¾     | ¾      | 1¼             | 1250                     |
| HPRTSH-30140 | 30   | 140 | 10   | 120   | 2             | 2½              | 2            | 1¼            | 1¼    | ¾     | ¾     | ¾      | 1¼             | 1630                     |
| HPRTSH-36143 | 36   | 143 | 11½  | 120   | 2½            | 3               | 2            | 1½            | 1½    | ¾     | ¾     | ¾      | 1¼             | 2020                     |
| HPRTSH-42146 | 42   | 146 | 13   | 120   | 2½            | 3               | 2½           | 1½            | 2     | ¾     | ¾     | ¾      | 1¼             | 2460                     |
| HPRTSH-48221 | 48   | 221 | 14½  | 192   | 3             | 4               | 3            | 2             | 2     | ¾     | 1     | ¾      | 1¼             | 4050                     |
| HPRTSH-54224 | 54   | 224 | 16   | 192   | 3             | 4               | 4            | 3             | 3     | ¾     | 1     | ¾      | 1¼             | 6060                     |
| HPRTSH-60227 | 60   | 227 | 17½  | 192   | 3             | 4               | 4            | 3             | 3     | ¾     | 1     | ¾      | 1¼             | 6870                     |
| HPRTSH-72281 | 72   | 281 | 20½  | 240   | 4             | 5               | 5            | 4             | 4     | ¾     | 1     | 1      | 1¼             | 12460                    |
| HPRTSH-84287 | 84   | 287 | 23½  | 240   | 5             | 6               | 6            | 4             | 4     | ¾     | 1     | 1¼     | 1¼             | 15040                    |
| HPRTSH-96293 | 96   | 293 | 26½  | 240   | 5             | 6               | 8            | 4             | 4     | ¾     | 1     | 1¼     | 1¼             | 21240                    |

All vessels are custom-built to customer specifications. Vessel dimensions and nozzle sizes in tables are suggestions for nominal conditions.

# Vertical Controlled Pressure Receiver

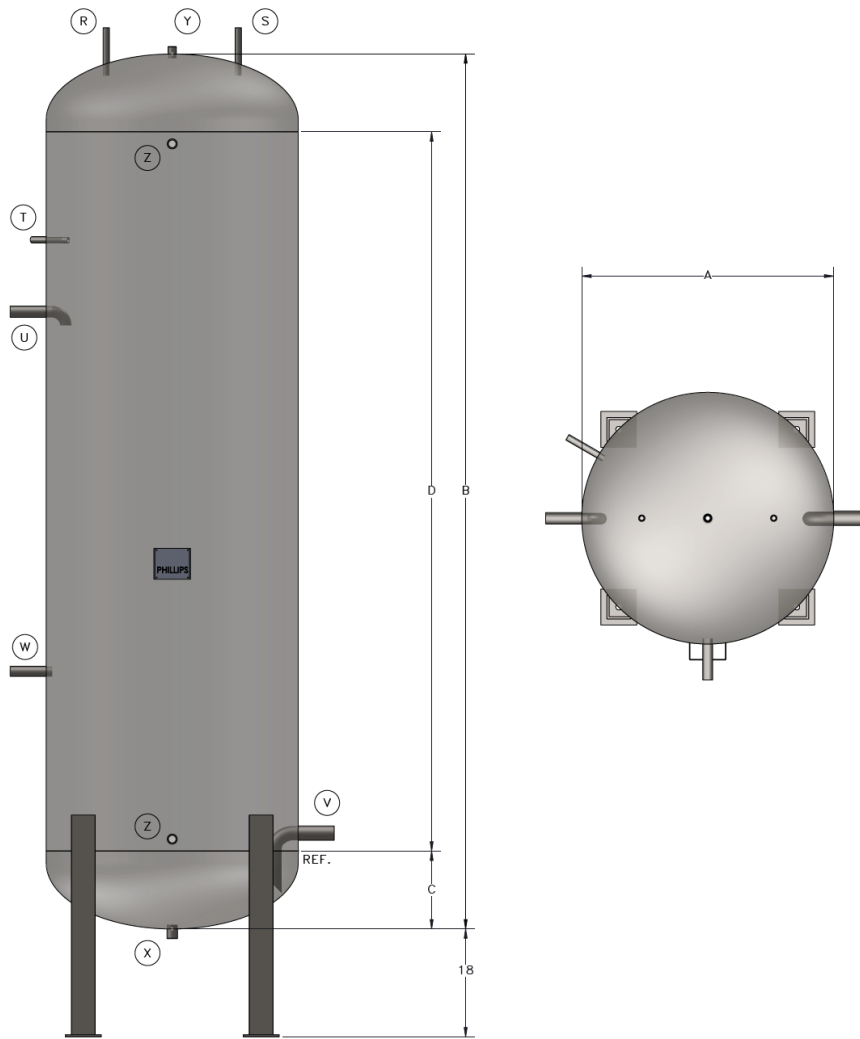

| Model No.  | A    | B   | C    | D     | R         | S          | T            | U          | V           | W                | X     | Y      | Z              | Est. Shipping Wt. (lbs.) |
|------------|------|-----|------|-------|-----------|------------|--------------|------------|-------------|------------------|-------|--------|----------------|--------------------------|
|            | Dia. | OAH | Head | Shell | Gas Inlet | Gas Outlet | Oil Pot Vent | Liq. Inlet | Liq. Outlet | Liq Trans. Inlet | Drain | Relief | Column (Qty 2) |                          |
| CPRV-20144 | 20   | 144 | 7½   | 129   | ¾         | ¾          | ¾            | ¾          | 1¼          | ¾                | 1     | ¾      | 1¼             | 740                      |
| CPRV-24144 | 24   | 144 | 8½   | 127   | ¾         | ¾          | ¾            | 1          | 1¼          | ¾                | 1     | ¾      | 1¼             | 1260                     |
| CPRV-24192 | 24   | 192 | 8½   | 175   | ¾         | ¾          | ¾            | 1¼         | 1½          | ¾                | 1     | ¾      | 1¼             | 1640                     |
| CPRV-30140 | 30   | 140 | 10   | 120   | ¾         | ¾          | ¾            | 1¼         | 1½          | ¾                | 1     | ¾      | 1¼             | 1590                     |
| CPRV-36143 | 36   | 143 | 11½  | 120   | ¾         | ¾          | ¾            | 1¼         | 2           | ¾                | 1     | ¾      | 1¼             | 1940                     |
| CPRV-42146 | 42   | 146 | 13   | 120   | ¾         | ¾          | ¾            | 1½         | 2           | 1¼               | 1     | ¾      | 1¼             | 2360                     |
| CPRV-48149 | 48   | 149 | 14½  | 120   | ¾         | 1¼         | ¾            | 2          | 2½          | 1¼               | 1     | ¾      | 1¼             | 2750                     |
| CPRV-48197 | 48   | 197 | 14½  | 168   | ¾         | 1¼         | ¾            | 2          | 2½          | 1¼               | 1     | ¾      | 1¼             | 3520                     |
| CPRV-54152 | 54   | 152 | 16   | 120   | ¾         | 1¼         | ¾            | 2          | 3           | 1¼               | 1     | ¾      | 1¼             | 4150                     |
| CPRV-54200 | 54   | 200 | 16   | 168   | ¾         | 1¼         | ¾            | 2          | 3           | 1¼               | 1     | ¾      | 1¼             | 5300                     |
| CPRV-60155 | 60   | 155 | 17½  | 120   | ¾         | 1¼         | ¾            | 2          | 3           | 2                | 1¼    | ¾      | 1¼             | 4750                     |
| CPRV-60203 | 60   | 203 | 17½  | 168   | ¾         | 1½         | ¾            | 2½         | 4           | 2                | 1¼    | ¾      | 1¼             | 6040                     |
| CPRV-72161 | 72   | 161 | 20½  | 120   | ¾         | 1½         | ¾            | 2½         | 4           | 2                | 1¼    | ¾      | 1¼             | 7550                     |
| CPRV-72209 | 72   | 209 | 20½  | 168   | ¾         | 2          | ¾            | 3          | 4           | 2                | 1¼    | ¾      | 1¼             | 9480                     |
| CPRV-84167 | 84   | 167 | 23½  | 120   | ¾         | 2          | 1            | 3          | 4           | 3                | 1½    | ¾      | 1¼             | 9260                     |
| CPRV-84215 | 84   | 215 | 23½  | 168   | ¾         | 2          | 1            | 3          | 4           | 3                | 1½    | 1      | 1¼             | 13690                    |
| CPRV-84239 | 84   | 239 | 23½  | 192   | 1         | 2          | 1            | 3          | 4           | 3                | 1½    | 1      | 1¼             | 15030                    |
| CPRV-96173 | 96   | 173 | 26½  | 120   | 1         | 2          | 1            | 3          | 4           | 3                | 1½    | ¾      | 1¼             | 13400                    |
| CPRV-96221 | 96   | 221 | 26½  | 168   | 1         | 2          | 1            | 3          | 5           | 3                | 1½    | 1      | 1¼             | 16490                    |
| CPRV-96245 | 96   | 245 | 26½  | 192   | 1         | 2½         | 1            | 4          | 5           | 3                | 1½    | 1      | 1¼             | 18030                    |

All vessels are custom-built to customer specifications. Vessel dimensions and nozzle sizes in tables are suggestions for nominal conditions.



Pilot Receiver

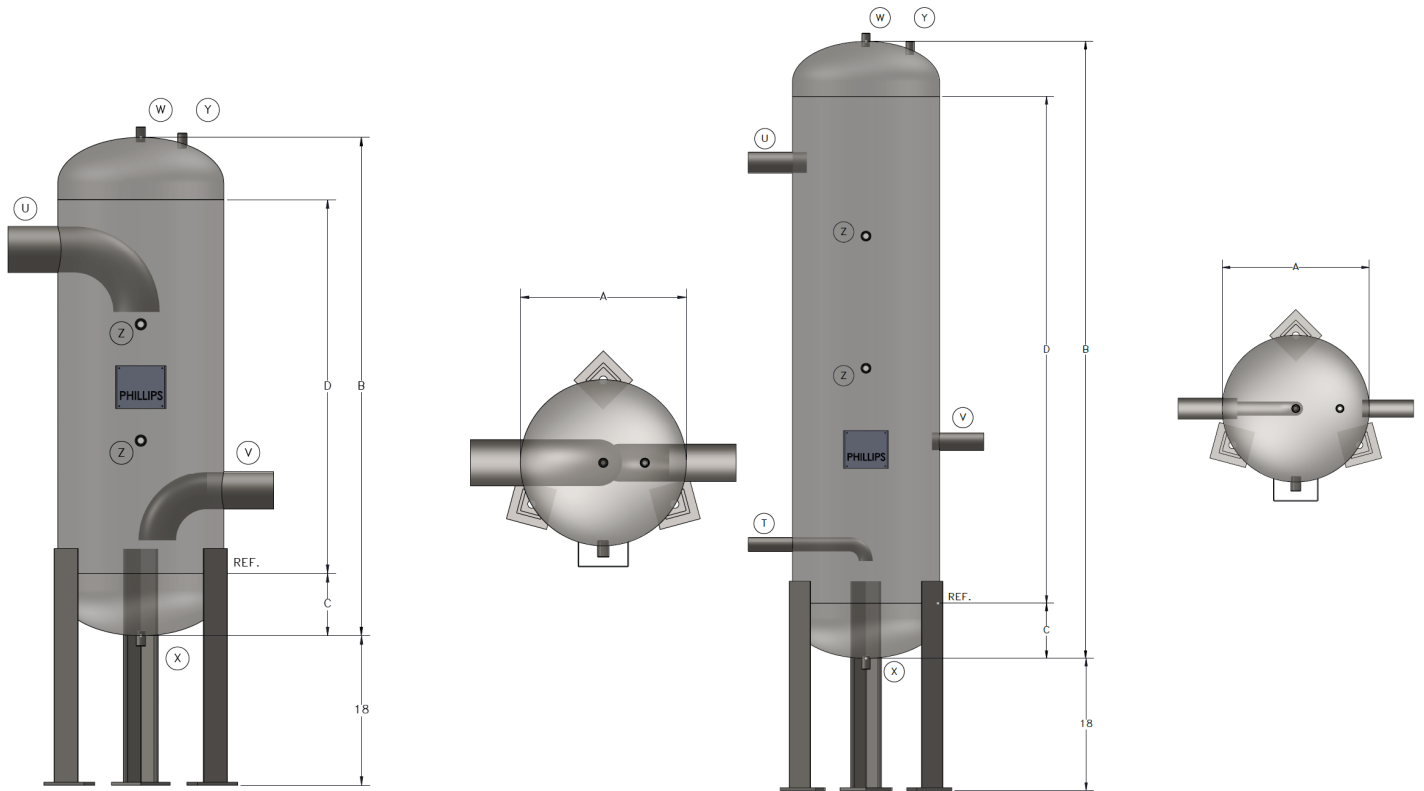

**PILOT RECEIVER FOR HIGH SIDE CONTROL**

| Model No. | A    | B   | C    | D     | U     | V      | W          | X     | Y      | Z             | Est. Shipping Wt. (lbs.) |
|-----------|------|-----|------|-------|-------|--------|------------|-------|--------|---------------|--------------------------|
| Model No. | Dia. | OAH | Head | Shell | Inlet | Outlet | Vent/Purge | Drain | Relief | Float (Qty 2) | Est. Shipping Wt. (lbs.) |
| PRV-1248A | 12   | 48  | 5½   | 37    | ¾     | ¾      | ¾          | ¾     | ½      | ¾             | 200                      |
| PRV-1248B | 12   | 48  | 5½   | 37    | 1     | ¾      | ¾          | ¾     | ½      | ¾             | 200                      |
| PRV-1248C | 12   | 48  | 5½   | 37    | 1¼    | 1      | ¾          | ¾     | ½      | ¾             | 200                      |
| PRV-1248D | 12   | 48  | 5½   | 37    | 1½    | 1¼     | ¾          | ¾     | ½      | ¾             | 200                      |
| PRV-1248E | 12   | 48  | 5½   | 37    | 2     | 1½     | ¾          | ¾     | ½      | ¾             | 200                      |
| PRV-1248F | 12   | 48  | 5½   | 37    | 2½    | 2      | ¾          | ¾     | ½      | ¾             | 200                      |
| PRV-1648A | 16   | 48  | 6½   | 35    | 3     | 2½     | ¾          | ¾     | ½      | ¾             | 250                      |
| PRV-1648B | 16   | 48  | 6½   | 35    | 4     | 3      | ¾          | ¾     | ½      | ¾             | 250                      |
| PRV-2060A | 20   | 60  | 7½   | 45    | 5     | 4      | ¾          | ¾     | ½      | ¾             | 380                      |

**PILOT RECEIVER FOR HIGH SIDE CONTROL WITH LIQUID INJECTION**

| Model No.   | A    | B   | C    | D     | T           | U     | V      | W          | X     | Y      | Z             | Est. Shipping Wt. (lbs.) |
|-------------|------|-----|------|-------|-------------|-------|--------|------------|-------|--------|---------------|--------------------------|
| Model No.   | Dia. | OAH | Head | Shell | Inj. Outlet | Inlet | Outlet | Vent/Purge | Drain | Relief | Float (Qty 2) | Est. Shipping Wt. (lbs.) |
| PRIV-1272A  | 12   | 72  | 5½   | 61    | 1¼          | ¾     | ¾      | ¾          | ¾     | ½      | ¾             | 270                      |
| PRIV-1284B  | 12   | 84  | 5½   | 73    | 1¼          | 1     | ¾      | ¾          | ¾     | ½      | ¾             | 300                      |
| PRIV-1672C  | 16   | 72  | 6½   | 59    | 1¼          | 1¼    | 1      | ¾          | ¾     | ½      | ¾             | 330                      |
| PRIV-1684D  | 16   | 84  | 6½   | 71    | 1½          | 1½    | 1¼     | ¾          | ¾     | ½      | ¾             | 370                      |
| PRIV-1696E  | 16   | 96  | 6½   | 83    | 1½          | 2     | 1½     | ¾          | ¾     | ¾      | ¾             | 410                      |
| PRIV-2084F  | 20   | 84  | 7½   | 69    | 1½          | 2½    | 2      | ¾          | ¾     | ¾      | ¾             | 480                      |
| PRIV-2484A  | 24   | 84  | 8½   | 67    | 2           | 3     | 2½     | ¾          | ¾     | ¾      | ¾             | 800                      |
| PRIV-24120B | 24   | 120 | 8½   | 103   | 2           | 4     | 3      | ¾          | ¾     | ¾      | ¾             | 1080                     |
| PRIV-30120A | 30   | 120 | 10   | 100   | 2½          | 5     | 4      | ¾          | ¾     | ¾      | ¾             | 1400                     |

All vessels are custom-built to customer specifications. Vessel dimensions and nozzle sizes in tables are suggestions for nominal conditions.

Thermo-Syphon Receiver

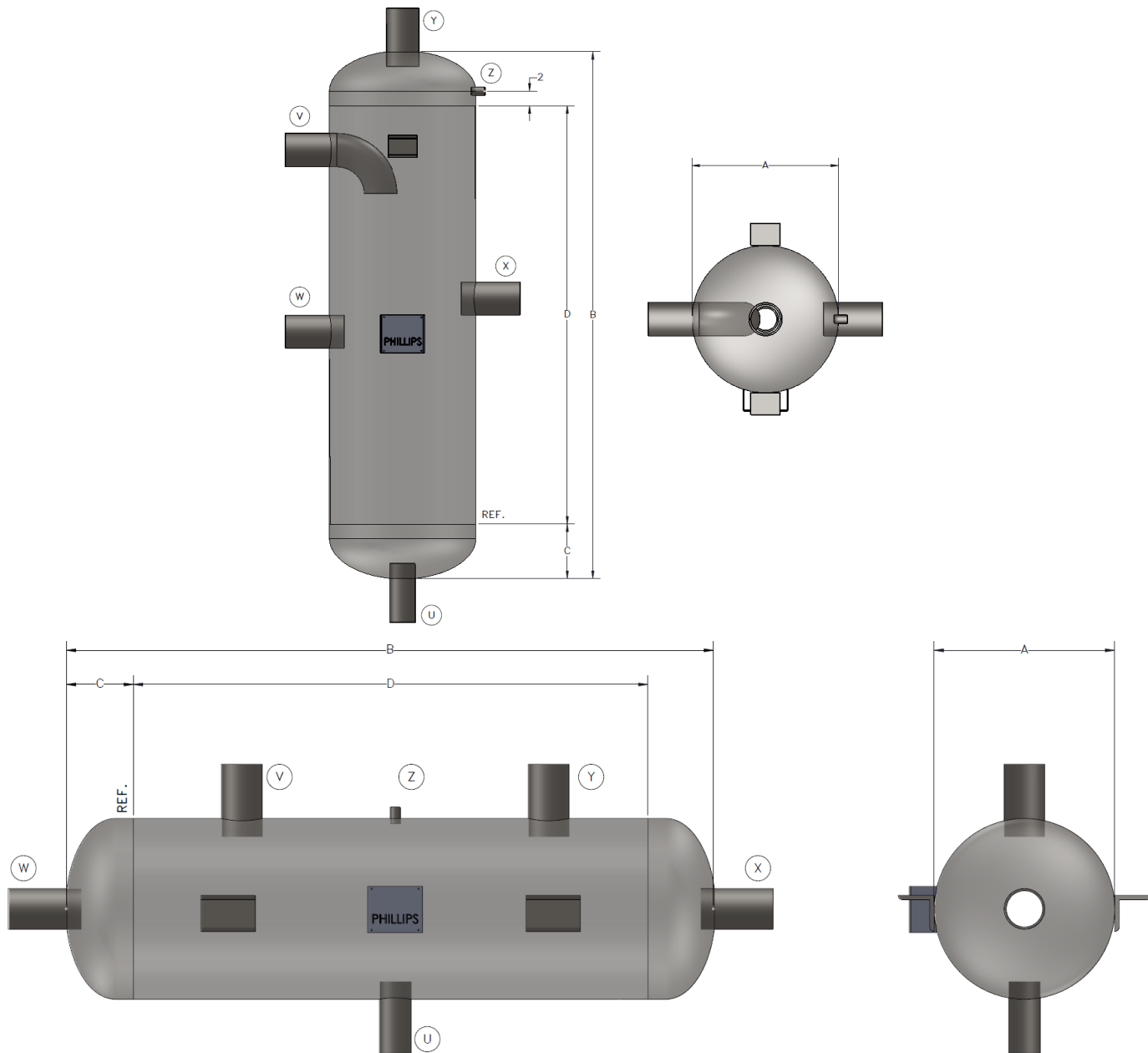

| Model No.* | Heat of Rejection [Btu/min]** | A<br>Dia. | B<br>OAL/OAH | C<br>Head | D<br>Shell | U<br>Oil Cooler Supply | V<br>Oil Cooler Return | W<br>Liq. Inlet | X<br>Liq. Outlet | Y<br>Vent | Z<br>Relief | Est. Shipping Wt. (lbs.) |
|------------|-------------------------------|-----------|--------------|-----------|------------|------------------------|------------------------|-----------------|------------------|-----------|-------------|--------------------------|
| TSR0836V/H | 1500                          | 8         | 36           | 4         | 28         | 1¼                     | 1½                     | 1½              | 1½               | 1½        | ½           | 120                      |
| TSR1048V/H | 3000                          | 10        | 48           | 5         | 38         | 1½                     | 2                      | 2               | 2                | 1½        | ½           | 170                      |
| TSR1060V/H | 4500                          | 10        | 60           | 5         | 50         | 2                      | 2½                     | 2½              | 2½               | 2         | ½           | 200                      |
| TSR1272V/H | 9000                          | 12        | 72           | 5½        | 61         | 2                      | 2½                     | 3               | 3                | 2½        | ½           | 260                      |
| TSR1672V/H | 15000                         | 16        | 72           | 6½        | 59         | 2½                     | 3                      | 4               | 4                | 3         | ½           | 370                      |
| TSR2072V/H | 22500                         | 20        | 72           | 7½        | 57         | 3                      | 4                      | 4               | 4                | 4         | ¾           | 450                      |
| TSR2472V/H | 30000                         | 24        | 72           | 8½        | 55         | 4                      | 5                      | 5               | 5                | 4         | ¾           | 730                      |
| TSR3072V/H | 45000                         | 30        | 72           | 10        | 52         | 5                      | 6                      | 5               | 5                | 5         | ¾           | 920                      |
| TSR3084V/H | 60000                         | 30        | 84           | 10        | 64         | 5                      | 6                      | 6               | 6                | 5         | ¾           | 1040                     |

\* Specify vertical or horizontal vessel by indicating "V" or "H" suffix in model number

\*\* Capacities listed are for R-717. For R-22, multiply Heat of Rejection by 0.3

All vessels are custom-built to customer specifications. Vessel dimensions and nozzle sizes in tables are suggestions for nominal conditions.

Vertical Intercooler

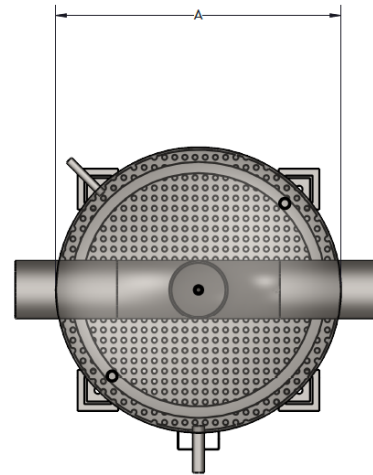
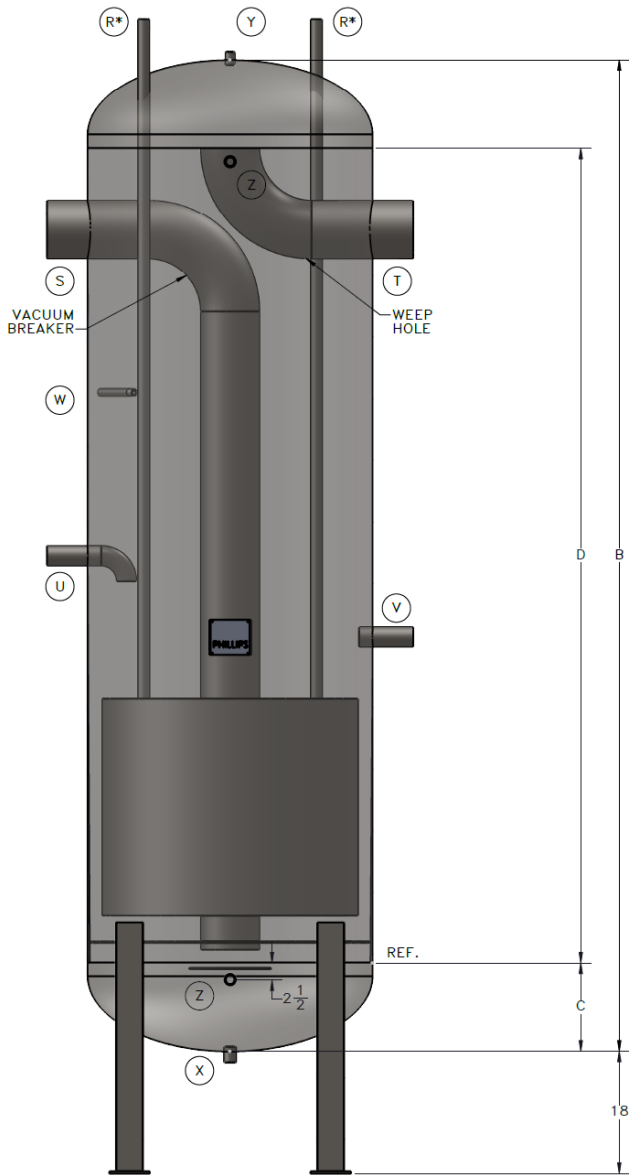

\*COIL IS OPTIONAL

| Model No. | A<br>Dia. | B<br>OAH | C<br>Head | D<br>Shell | OPTIONAL<br>Coil | OPTIONAL<br>Coil Conn.<br>(Qty 2) | R<br>Inlet | S<br>Outlet | T<br>Liquid<br>Makeup | U<br>Liquid Out | V<br>Oil Pot<br>Vent | W<br>Drain | X<br>Relief | Y<br>Column<br>(Qty 2) | Z  | *Est.<br>Shipping<br>Wt. (lbs.) |
|-----------|-----------|----------|-----------|------------|------------------|-----------------------------------|------------|-------------|-----------------------|-----------------|----------------------|------------|-------------|------------------------|----|---------------------------------|
| ICV-1696  | 16        | 96       | 6½        | 83         | S-W,23.5T        | ¾                                 | 3          | 3           | ¾                     | ¾               | ¾                    | 1          | ¾           | 1¼                     | 1¼ | 730                             |
| ICV-2096  | 20        | 96       | 7½        | 81         | D-W,16.5T        | ¾                                 | 4          | 4           | 1                     | 1               | ¾                    | 1          | ¾           | 1¼                     | 1¼ | 850                             |
| ICV-2496  | 24        | 96       | 8½        | 79         | D-W,14.5T        | 1                                 | 5          | 5           | 1¼                    | 1¼              | ¾                    | 1          | ¾           | 1¼                     | 1¼ | 1360                            |
| ICV-30116 | 30        | 116      | 10        | 96         | D-W,15.5T        | 1¼                                | 6          | 6           | 1½                    | 1½              | ¾                    | 1          | ¾           | 1¼                     | 1¼ | 2250                            |
| ICV-36119 | 36        | 119      | 11½       | 96         | D-W,17.5T        | 1¼                                | 8          | 8           | 2                     | 2               | ¾                    | 1          | ¾           | 1¼                     | 1¼ | 2990                            |
| ICV-42122 | 42        | 122      | 13        | 96         | D-W,16.5T        | 1¼                                | 8          | 8           | 2½                    | 2½              | ¾                    | 1          | ¾           | 1¼                     | 1¼ | 3580                            |
| ICV-48149 | 48        | 149      | 14½       | 120        | T-W,13.5T        | 1½                                | 10         | 10          | 2½                    | 2½              | ¾                    | 1          | ¾           | 1¼                     | 1¼ | 5350                            |
| ICV-54152 | 54        | 152      | 16        | 120        | T-W,12.5T        | 2                                 | 10         | 10          | 3                     | 3               | ¾                    | 1          | ¾           | 1¼                     | 1¼ | 7620                            |
| ICV-60155 | 60        | 155      | 17½       | 120        | T-W,13.5T        | 2                                 | 12         | 12          | 3                     | 3               | ¾                    | 1¼         | ¾           | 1¼                     | 1¼ | 9060                            |
| ICV-72161 | 72        | 161      | 20½       | 120        | Q-W,16.5T        | 1½                                | 14         | 14          | 4                     | 4               | ¾                    | 1¼         | ¾           | 1¼                     | 1¼ | 12740                           |
| ICV-84167 | 84        | 167      | 23½       | 120        | Q-W,17.5T        | 2                                 | 16         | 16          | 5                     | 5               | ¾                    | 1½         | ¾           | 1¼                     | 1¼ | 15440                           |
| ICV-96173 | 96        | 173      | 26½       | 120        | Q-W,18.5T        | 2½                                | 18         | 18          | 5                     | 5               | ¾                    | 1½         | ¾           | 1¼                     | 1¼ | 20360                           |

\*Optional coil included in estimated vessel shipping weight.

All vessels are custom-built to customer specifications. Vessel dimensions and nozzle sizes in tables are suggestions for nominal conditions.

Vertical Suction Accumulator (for use with transfer systems)

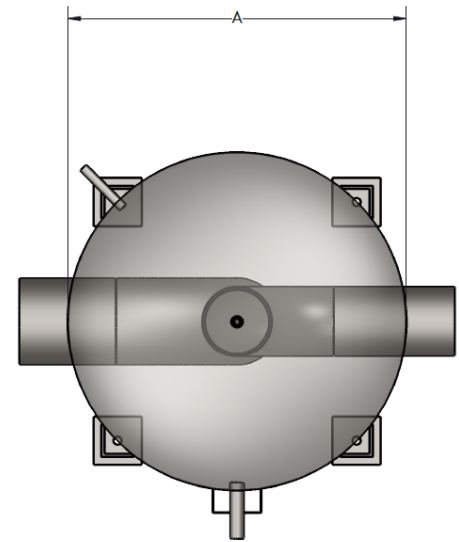
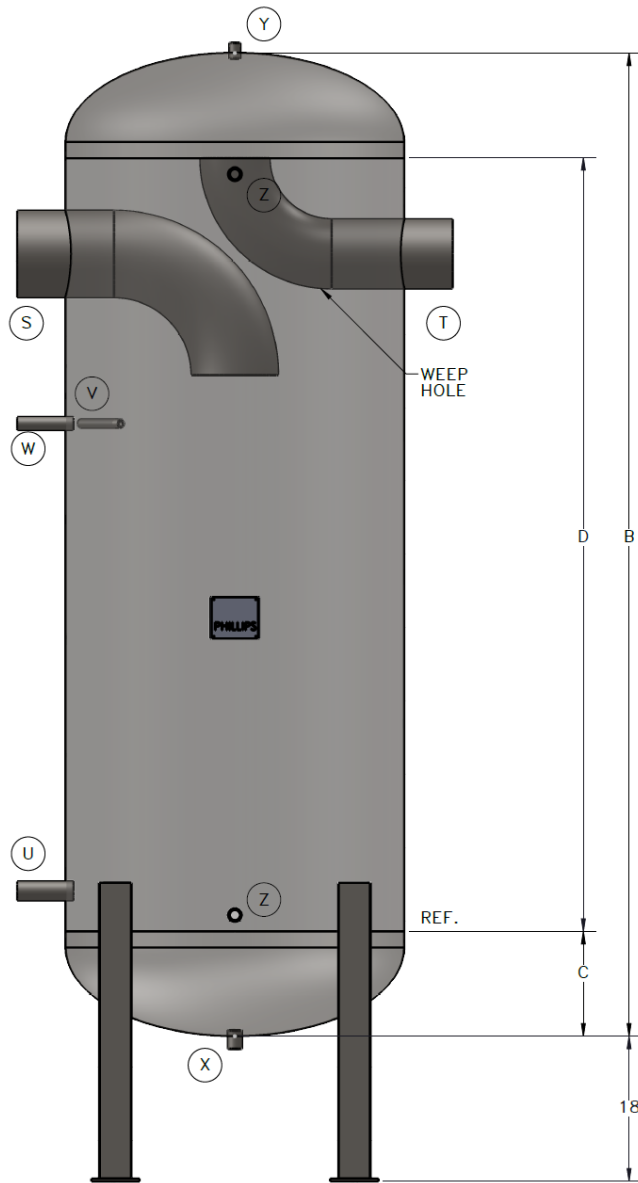

| Model No. | A    | B   | C    | D     | S             | T              | U          | V            | W          | X     | Y      | Z              | Est. Shipping Wt. (lbs.) |
|-----------|------|-----|------|-------|---------------|----------------|------------|--------------|------------|-------|--------|----------------|--------------------------|
|           | Dia. | OAH | Head | Shell | Suction Inlet | Suction Outlet | Liquid Out | Oil Pot Vent | 3-Way Vent | Drain | Relief | Column (Qty 2) |                          |
| ACV-1272  | 12   | 72  | 5½   | 61    | 3             | 3              | 1¼         | ¾            | ¾          | 1     | ½      | 1¼             | 290                      |
| ACV-1696  | 16   | 96  | 6½   | 83    | 4             | 3              | 1¼         | ¾            | ¾          | 1     | ¾      | 1¼             | 440                      |
| ACV-2096  | 20   | 96  | 7½   | 81    | 5             | 4              | 1¼         | ¾            | ¾          | 1     | ¾      | 1¼             | 560                      |
| ACV-2496  | 24   | 96  | 8½   | 79    | 6             | 5              | 1¼         | ¾            | ¾          | 1     | ¾      | 1¼             | 950                      |
| ACV-30116 | 30   | 116 | 10   | 96    | 8             | 6              | 1½         | ¾            | ¾          | 1     | ¾      | 1¼             | 1450                     |
| ACV-36119 | 36   | 119 | 11½  | 96    | 10            | 8              | 2          | ¾            | ¾          | 1     | ¾      | 1¼             | 1830                     |
| ACV-42122 | 42   | 122 | 13   | 96    | 10            | 8              | 2          | ¾            | ¾          | 1     | ¾      | 1¼             | 2220                     |
| ACV-48149 | 48   | 149 | 14½  | 120   | 10            | 8              | 3          | ¾            | 1¼         | 1     | ¾      | 1¼             | 2970                     |
| ACV-54152 | 54   | 152 | 16   | 120   | 12            | 10             | 3          | ¾            | 1¼         | 1     | ¾      | 1¼             | 4470                     |
| ACV-60155 | 60   | 155 | 17½  | 120   | 12            | 12             | 3          | ¾            | 1¼         | 1¼    | ¾      | 1¼             | 5140                     |
| ACV-72161 | 72   | 161 | 20½  | 120   | 16            | 14             | 4          | ¾            | 1¼         | 1¼    | ¾      | 1¼             | 8130                     |
| ACV-84167 | 84   | 167 | 23½  | 120   | 18            | 16             | 4          | 1            | 1¼         | 1½    | ¾      | 1¼             | 10050                    |
| ACV-96173 | 96   | 173 | 26½  | 120   | 20            | 18             | (2) 4      | 1            | 2          | 1½    | ¾      | 1¼             | 14440                    |

All vessels are custom-built to customer specifications. Vessel dimensions and nozzle sizes in tables are suggestions for nominal conditions.

Horizontal Suction Accumulator (for use with transfer systems)

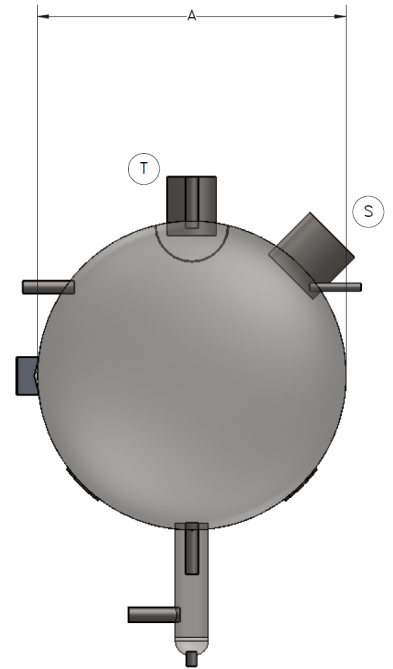
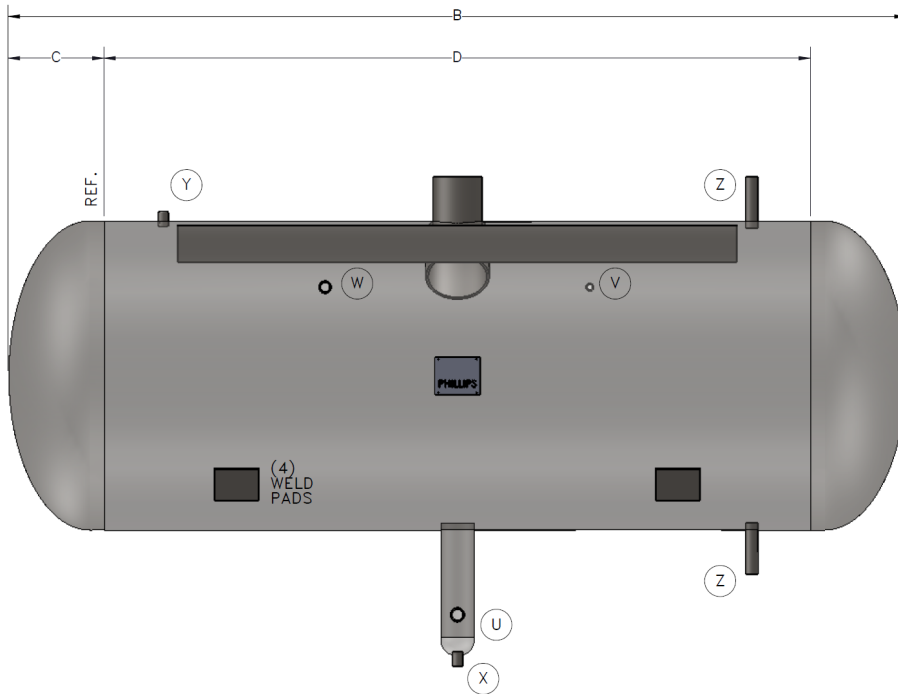

| Model No.  | A    | B   | C    | D     | Sump Dia. | Sump Length | S         | T          | U          | V            | W          | X     | Y      | Z              | Est. Shipping Wt. (lbs.) |
|------------|------|-----|------|-------|-----------|-------------|-----------|------------|------------|--------------|------------|-------|--------|----------------|--------------------------|
|            | Dia. | OAL | Head | Shell |           |             | Gas Inlet | Gas Outlet | Liquid Out | Oil Pot Vent | 3-Way Vent | Drain | Relief | Column (Qty 2) |                          |
| ACH-30140  | 30   | 140 | 10   | 120   | 4         | 18          | 6         | 5          | 1¼         | ¾            | ¾          | 1     | ¾      | 1¼             | 1880                     |
| ACH-36143  | 36   | 143 | 11½  | 120   | 4         | 18          | 8         | 6          | 1¼         | ¾            | ¾          | 1     | ¾      | 1¼             | 2250                     |
| ACH-42146  | 42   | 146 | 13   | 120   | 4         | 18          | 8         | 6          | 1½         | ¾            | 1¼         | 1     | ¾      | 1¼             | 2620                     |
| ACH-48149  | 48   | 149 | 14½  | 120   | 4         | 18          | 8         | 6          | 2          | ¾            | 1¼         | 1     | ¾      | 1¼             | 3000                     |
| ACH-54152  | 54   | 152 | 16   | 120   | 6         | 18          | 10        | 8          | 2          | ¾            | 1¼         | 1     | ¾      | 1¼             | 4490                     |
| ACH-60155  | 60   | 155 | 17½  | 120   | 6         | 18          | 10        | 8          | 2          | ¾            | 1¼         | 1¼    | ¾      | 1¼             | 5860                     |
| ACH-72161  | 72   | 161 | 20½  | 120   | 8         | 18          | 12        | 10         | 3          | ¾            | 1¼         | 1¼    | ¾      | 1¼             | 7830                     |
| ACH-84167  | 84   | 167 | 23½  | 120   | 8         | 20          | 12        | 12         | 3          | 1            | 1¼         | 1½    | ¾      | 1¼             | 9530                     |
| ACH-96173  | 96   | 173 | 26½  | 120   | 10        | 20          | 14        | 12         | 4          | 1            | 1¼         | 1½    | ¾      | 1¼             | 13390                    |
| ACH-108179 | 108  | 179 | 29½  | 120   | 10        | 20          | 16        | 14         | 4          | 1            | 1¼         | 1½    | 1      | 1¼             | 18180                    |
| ACH-120185 | 120  | 185 | 32½  | 120   | 10        | 20          | 18        | 16         | 4          | 1            | 1¼         | 1½    | 1      | 1¼             | 23980                    |
| ACH-144197 | 144  | 197 | 38½  | 120   | 12        | 20          | 20        | 18         | (2) 4      | 1            | 2          | 1½    | 1¼     | 1¼             | 36270                    |

All vessels are custom-built to customer specifications. Vessel dimensions and nozzle sizes in tables are suggestions for nominal conditions.

Vertical Suction Accumulator with Boil-Out Coil

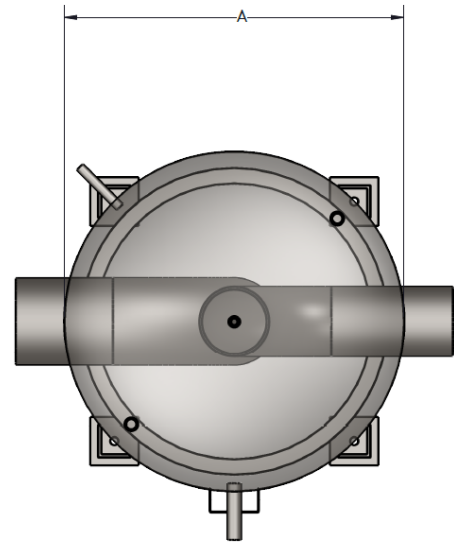
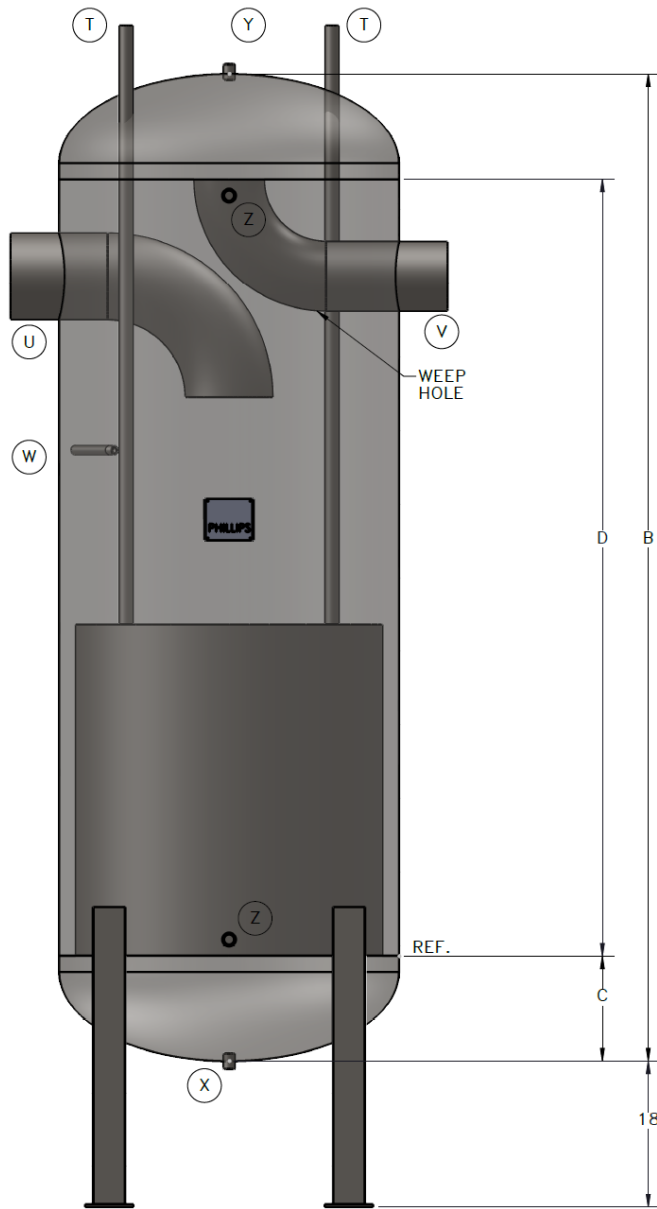

| Model No.  | A<br>Dia. | B<br>OAH | C<br>Head | D<br>Shell | Coil      | Alternate<br>Coil | T<br>Coil Conn.<br>(Qty 2) | U<br>Suction<br>Inlet | V<br>Suction<br>Outlet | W<br>Oil Pot<br>Vent | X<br>Drain | Y<br>Relief | Z<br>Column<br>(Qty 2) | *Est.<br>Shipping<br>Wt. (lbs.) |
|------------|-----------|----------|-----------|------------|-----------|-------------------|----------------------------|-----------------------|------------------------|----------------------|------------|-------------|------------------------|---------------------------------|
| ACCV-1696  | 16        | 96       | 6½        | 83         | S-W,17.5T |                   | ¾                          | 4                     | 3                      | ¾                    | 1          | ¾           | 1¼                     | 640                             |
| ACCV-2096  | 20        | 96       | 7½        | 81         | S-W,17.5T |                   | 1                          | 5                     | 4                      | ¾                    | 1          | ¾           | 1¼                     | 780                             |
| ACCV-2496  | 24        | 96       | 8½        | 79         | S-W,17.5T |                   | 1                          | 6                     | 5                      | ¾                    | 1          | ¾           | 1¼                     | 1190                            |
| ACCV-30116 | 30        | 116      | 10        | 96         | S-W,20.5T |                   | 1¼                         | 8                     | 6                      | ¾                    | 1          | ¾           | 1¼                     | 1920                            |
| ACCV-36119 | 36        | 119      | 11½       | 96         | S-W,20.5T |                   | 1½                         | 10                    | 8                      | ¾                    | 1          | ¾           | 1¼                     | 2520                            |
| ACCV-42122 | 42        | 122      | 13        | 96         | S-W,18.5T | D-W,13.5T         | 1½                         | 10                    | 8                      | ¾                    | 1          | ¾           | 1¼                     | 2960                            |
| ACCV-48149 | 48        | 149      | 14½       | 120        | S-W,17.5T | D-W,12.5T         | 2                          | 10                    | 8                      | ¾                    | 1          | ¾           | 1¼                     | 3850                            |
| ACCV-54152 | 54        | 152      | 16        | 120        | S-W,17.5T | D-W,13.5T         | 2                          | 12                    | 10                     | ¾                    | 1          | ¾           | 1¼                     | 5450                            |
| ACCV-60155 | 60        | 155      | 17½       | 120        | S-W,17.5T | D-W,14.5T         | 2                          | 12                    | 12                     | ¾                    | 1¼         | ¾           | 1¼                     | 6230                            |
| ACCV-72161 | 72        | 161      | 20½       | 120        | S-W,17.5T | D-W,14.5T         | 2                          | 16                    | 14                     | ¾                    | 1¼         | ¾           | 1¼                     | 9220                            |
| ACCV-84167 | 84        | 167      | 23½       | 120        | S-W,17.5T | D-W,14.5T         | 2                          | 18                    | 16                     | 1                    | 1½         | ¾           | 1¼                     | 11140                           |
| ACCV-96173 | 96        | 173      | 26½       | 120        | S-W,17.5T | D-W,14.5T         | 2                          | 20                    | 18                     | 1                    | 1½         | ¾           | 1¼                     | 15540                           |

\*Single wound coil included in estimated vessel shipping weight.

All vessels are custom-built to customer specifications. Vessel dimensions and nozzle sizes in tables are suggestions for nominal conditions.

Economizer

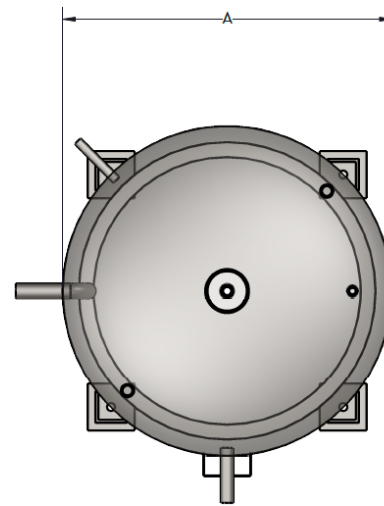
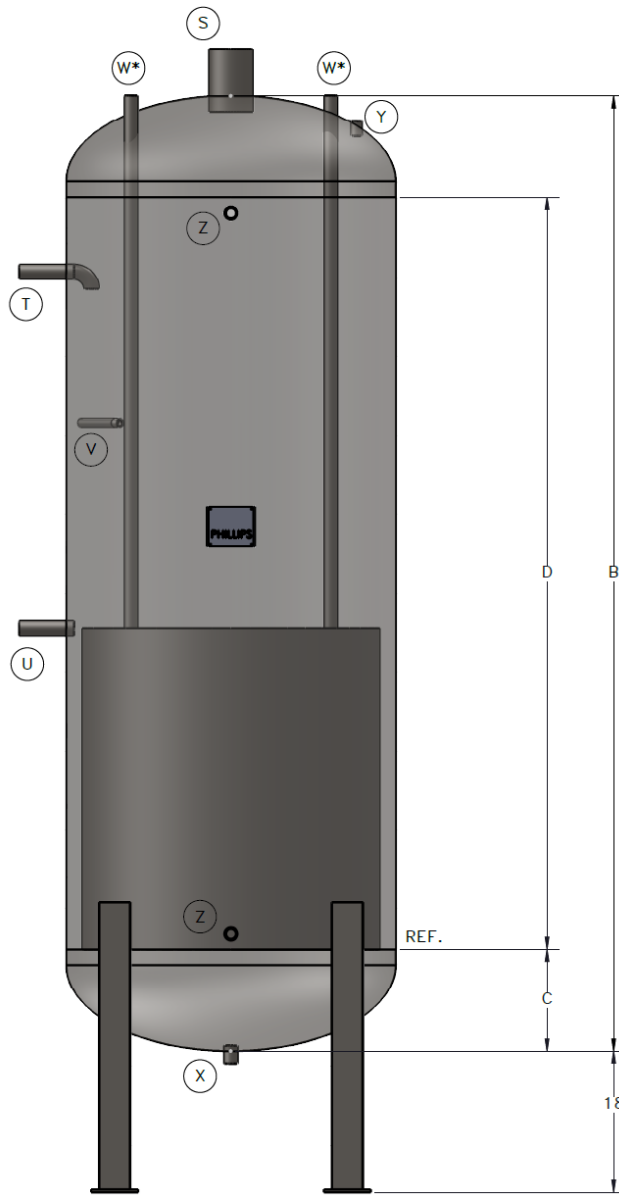

\*COIL IS OPTIONAL

| Model No.  | A  | B   | C      | D   | Optional Coil | S     | T     | U     | V   | W     | X     | Y   | Z     | Econ. Tons | Sys. Tons | *Est. Shipping Wt. (lbs.) |
|------------|----|-----|--------|-----|---------------|-------|-------|-------|-----|-------|-------|-----|-------|------------|-----------|---------------------------|
| ECON-1084  | 10 | 84  | 5      | 74  |               | 3/4   | 3/4   | 3/4   | 3/4 | 1/2   | 1     | 1/2 | 1 1/4 | 7          | 43        | 260                       |
| ECON-1284  | 12 | 84  | 5 1/2  | 73  |               | 1     | 3/4   | 3/4   | 3/4 | 1/2   | 1     | 1/2 | 1 1/4 | 12         | 62        | 300                       |
| ECON-1696  | 16 | 96  | 6 1/2  | 83  | S-W,23.5T     | 1 1/4 | 1     | 1     | 3/4 | 3/4   | 1     | 3/4 | 1 1/4 | 20         | 98        | 620                       |
| ECON-2096  | 20 | 96  | 7 1/2  | 81  | D-W,16.5T     | 1 1/2 | 1     | 1     | 3/4 | 3/4   | 1     | 3/4 | 1 1/4 | 31         | 155       | 720                       |
| ECON-2496  | 24 | 96  | 8 1/2  | 79  | D-W,14.5T     | 2     | 1     | 1     | 3/4 | 1     | 1     | 3/4 | 1 1/4 | 51         | 225       | 1130                      |
| ECON-30116 | 30 | 116 | 10     | 96  | D-W,15.5T     | 2 1/2 | 1 1/2 | 1 1/2 | 3/4 | 1 1/4 | 1     | 3/4 | 1 1/4 | 75         | 350       | 1820                      |
| ECON-36119 | 36 | 119 | 11 1/2 | 96  | D-W,17.5T     | 2 1/2 | 1 1/2 | 1 1/2 | 3/4 | 1 1/4 | 1     | 3/4 | 1 1/4 | 75         | 508       | 2320                      |
| ECON-42122 | 42 | 122 | 13     | 96  | D-W,16.5T     | 3     | 1 1/2 | 1 1/2 | 3/4 | 1 1/4 | 1     | 3/4 | 1 1/4 | 122        | 696       | 2750                      |
| ECON-48149 | 48 | 149 | 14 1/2 | 120 | T-W,13.5T     | 4     | 2     | 2     | 3/4 | 1 1/2 | 1     | 3/4 | 1 1/4 | 203        | 913       | 3600                      |
| ECON-54152 | 54 | 152 | 16     | 120 | T-W,12.5T     | 4     | 2     | 2     | 3/4 | 2     | 1     | 3/4 | 1 1/4 | 203        | 1150      | 5130                      |
| ECON-60155 | 60 | 155 | 17 1/2 | 120 | T-W,13.5T     | 5     | 2 1/2 | 2 1/2 | 3/4 | 2     | 1 1/4 | 3/4 | 1 1/4 | 308        | 1425      | 5840                      |

System Tons at +55°F/+95°F

Economizer Tons based on suction outlet line size at +55°F/+95°F

\*Optional coil included in estimated vessel shipping weight.

All vessels are custom-built to customer specifications. Vessel dimensions and nozzle sizes in tables are suggestions for nominal conditions.

# Horizontal Surge Drum

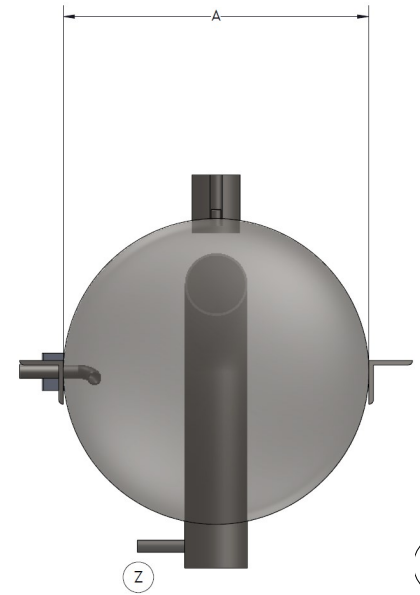
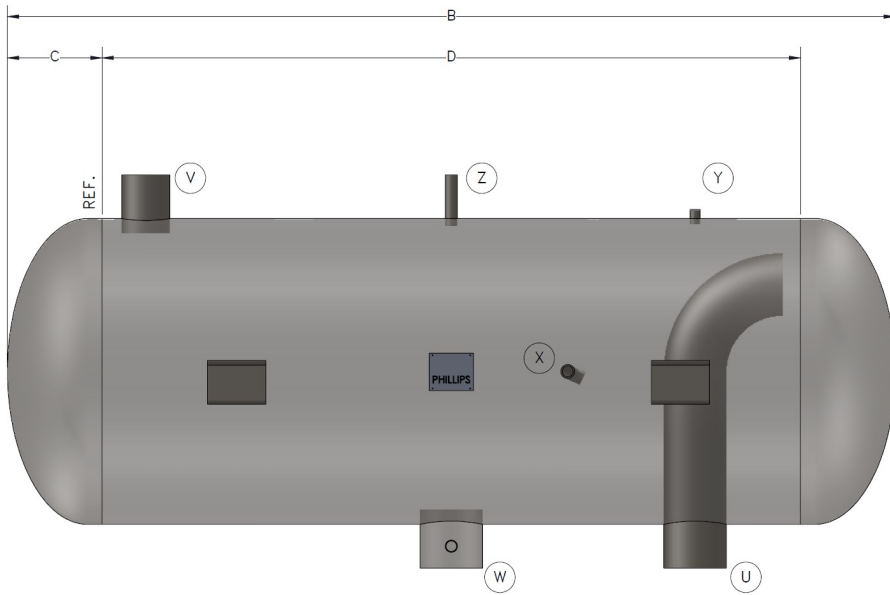

|           | A    | B   | C    | D     | U         | V          | W          | X      | Y      | Z              |                          |
|-----------|------|-----|------|-------|-----------|------------|------------|--------|--------|----------------|--------------------------|
| Model No. | Dia. | OAL | Head | Shell | Gas Inlet | Gas Outlet | Liquid Leg | Makeup | Relief | Column (Qty 2) | Est. Shipping Wt. (lbs.) |
| SDH-12048 | 12   | 48  | 5½   | 37    | 2½        | 2          | 3          | ¾      | ½      | 1¼             | 200                      |
| SDH-16060 | 16   | 60  | 6½   | 47    | 3         | 2½         | 4          | ¾      | ½      | 1¼             | 330                      |
| SDH-20072 | 20   | 72  | 7½   | 57    | 4         | 3          | 4          | ¾      | ¾      | 1¼             | 450                      |
| SDH-24072 | 24   | 72  | 8½   | 55    | 4         | 4          | 4          | 1      | ¾      | 1¼             | 730                      |
| SDH-30092 | 30   | 92  | 10   | 72    | 5         | 4          | 5          | 1¼     | ¾      | 1¼             | 1140                     |
| SDH-36095 | 36   | 95  | 11½  | 72    | 6         | 5          | 6          | 1½     | ¾      | 1¼             | 1410                     |
| SDH-42122 | 42   | 122 | 13   | 96    | 8         | 6          | 8          | 1½     | ¾      | 1¼             | 2150                     |
| SDH-48149 | 48   | 149 | 14½  | 120   | 8         | 8          | 8          | 2      | ¾      | 1¼             | 2880                     |
| SDH-54152 | 54   | 152 | 16   | 120   | 8         | 8          | 8          | 2½     | ¾      | 1¼             | 4280                     |
| SDH-60155 | 60   | 155 | 17½  | 120   | 10        | 8          | 10         | 2½     | ¾      | 1¼             | 4920                     |
| SDH-72161 | 72   | 161 | 20½  | 120   | 10        | 10         | 10         | 3      | ¾      | 1¼             | 7660                     |
| SDH-84167 | 84   | 167 | 23½  | 120   | 12        | 10         | 12         | 3      | ¾      | 1¼             | 9480                     |
| SDH-96173 | 96   | 173 | 26½  | 120   | 12        | 12         | 12         | 4      | ¾      | 1¼             | 13350                    |

All vessels are custom-built to customer specifications. Vessel dimensions and nozzle sizes in tables are suggestions for nominal conditions.



Vertical Surge Drum

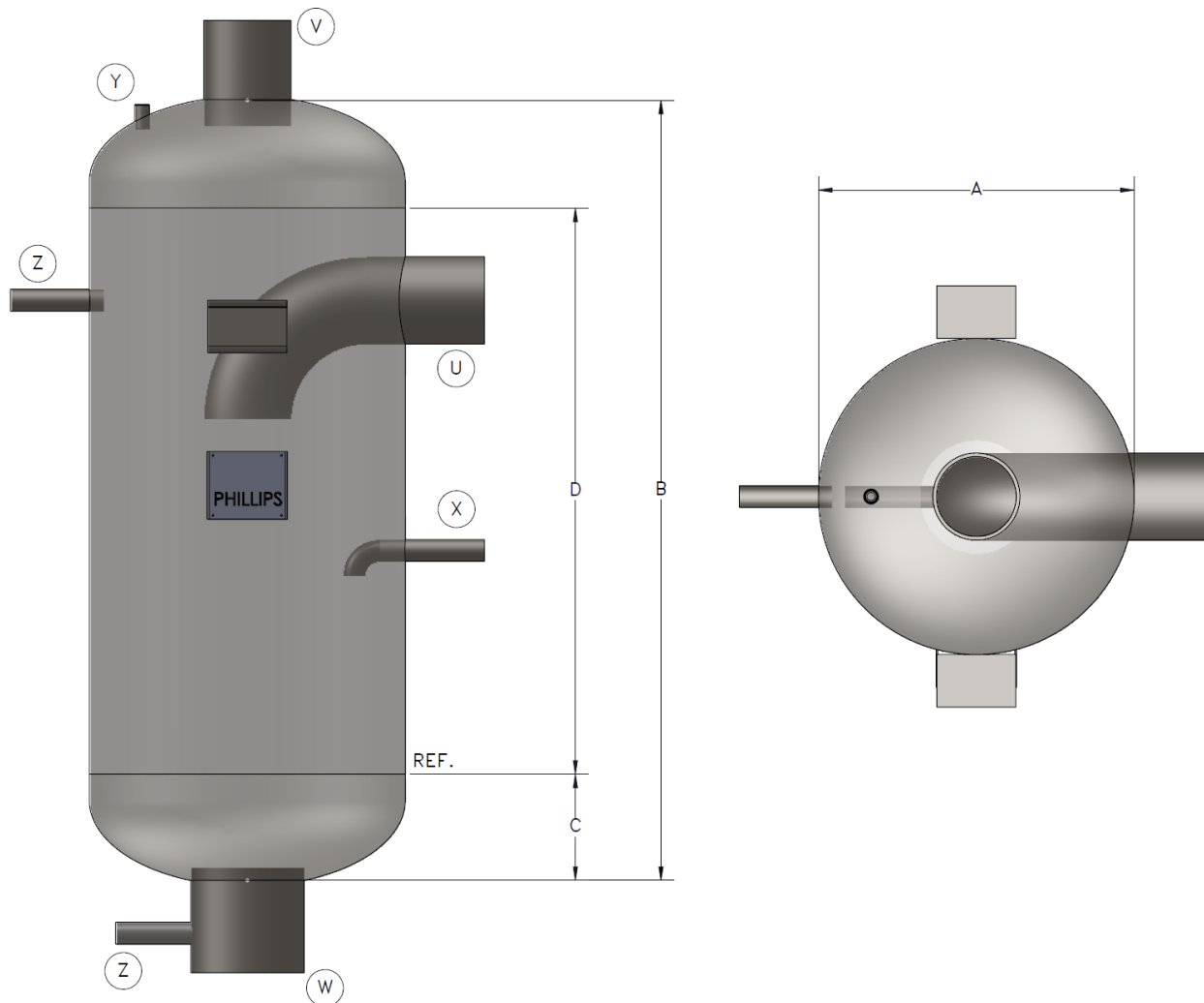

|           | A    | B   | C    | D     | U         | V          | W          | X      | Y      | Z              |                          |
|-----------|------|-----|------|-------|-----------|------------|------------|--------|--------|----------------|--------------------------|
| Model No. | Dia. | OAH | Head | Shell | Gas Inlet | Gas Outlet | Liquid Leg | Makeup | Relief | Column (Qty 2) | Est. Shipping Wt. (lbs.) |
| SDV-12048 | 12   | 48  | 5½   | 37    | 4         | 3          | 4          | ¾      | ½      | 1¼             | 200                      |
| SDV-16054 | 16   | 54  | 6½   | 41    | 5         | 4          | 5          | ¾      | ½      | 1¼             | 370                      |
| SDV-20060 | 20   | 60  | 7½   | 45    | 6         | 5          | 6          | 1      | ½      | 1¼             | 370                      |
| SDV-24060 | 24   | 60  | 8½   | 43    | 6         | 6          | 8          | 1¼     | ¾      | 1¼             | 620                      |
| SDV-30080 | 30   | 80  | 10   | 60    | 8         | 8          | 8          | 1½     | ¾      | 1¼             | 1020                     |
| SDV-36083 | 36   | 83  | 11½  | 60    | 10        | 8          | 10         | 2      | ¾      | 1¼             | 1330                     |
| SDV-42098 | 42   | 98  | 13   | 72    | 10        | 8          | 10         | 2½     | ¾      | 1¼             | 1760                     |
| SDV-48125 | 48   | 125 | 14½  | 96    | 10        | 8          | 10         | 2½     | ¾      | 1¼             | 2480                     |

All vessels are custom-built to customer specifications. Vessel dimensions and nozzle sizes in tables are suggestions for nominal conditions.

Horizontal Surge Drum - Split Flow Design

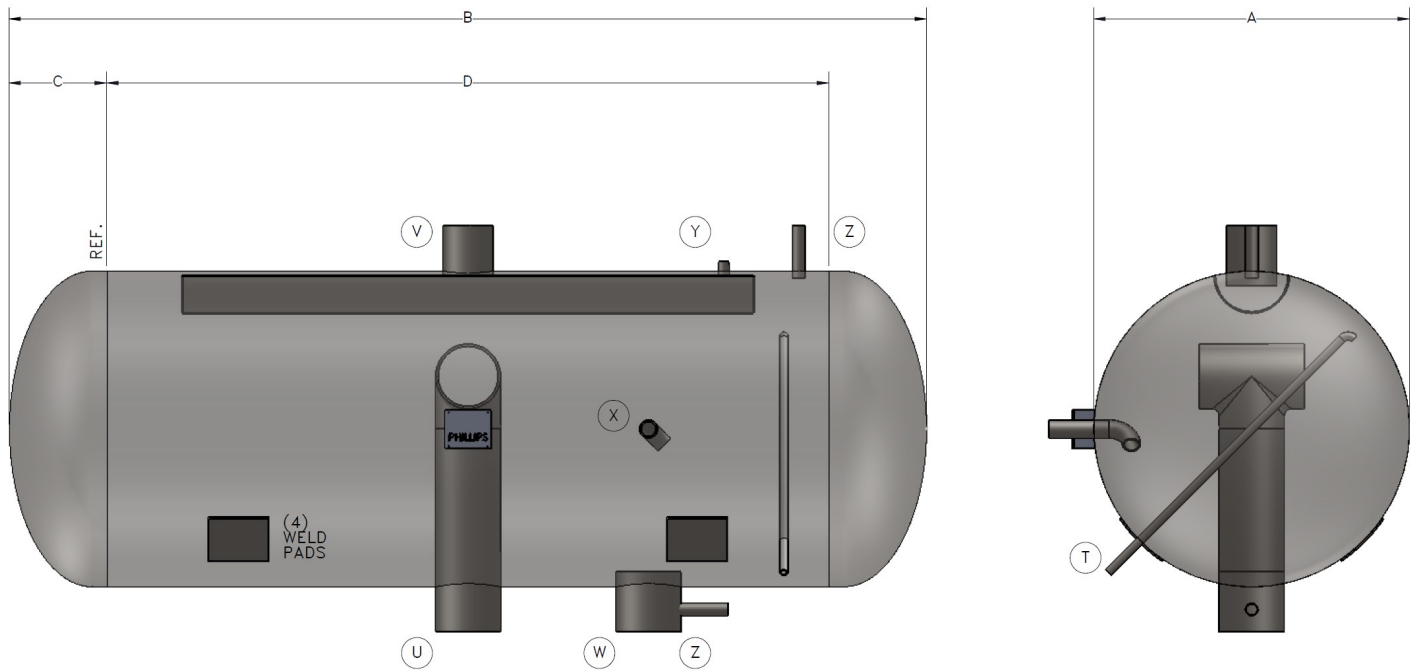

| Model No.   | A    | B   | C    | D     | T            | U         | V          | W          | X      | Y      | Z              | Est. Shipping Wt. (lbs.) |
|-------------|------|-----|------|-------|--------------|-----------|------------|------------|--------|--------|----------------|--------------------------|
|             | Dia. | OAL | Head | Shell | Oil Pot Vent | Gas Inlet | Gas Outlet | Liquid Leg | Makeup | Relief | Column (Qty 2) |                          |
| SFSDH-12048 | 12   | 48  | 5½   | 37    | ¾            | 4         | 3          | 4          | ¾      | ½      | 1¼             | 200                      |
| SFSDH-16060 | 16   | 60  | 6½   | 47    | ¾            | 4         | 3          | 4          | ¾      | ½      | 1¼             | 290                      |
| SFSDH-20072 | 20   | 72  | 7½   | 57    | ¾            | 5         | 4          | 5          | 1      | ¾      | 1¼             | 430                      |
| SFSDH-24072 | 24   | 72  | 8½   | 55    | ¾            | 6         | 5          | 6          | 1¼     | ¾      | 1¼             | 770                      |
| SFSDH-30092 | 30   | 92  | 10   | 72    | ¾            | 8         | 6          | 8          | 1½     | ¾      | 1¼             | 1340                     |
| SFSDH-36095 | 36   | 95  | 11½  | 72    | ¾            | 8         | 6          | 8          | 1½     | ¾      | 1¼             | 1600                     |
| SFSDH-42122 | 42   | 122 | 13   | 96    | ¾            | 10        | 8          | 10         | 2      | ¾      | 1¼             | 2440                     |
| SFSDH-48149 | 48   | 149 | 14½  | 120   | ¾            | 10        | 8          | 10         | 2½     | ¾      | 1¼             | 3270                     |
| SFSDH-54152 | 54   | 152 | 16   | 120   | ¾            | 10        | 10         | 10         | 2½     | ¾      | 1¼             | 4790                     |
| SFSDH-60155 | 60   | 155 | 17½  | 120   | ¾            | 12        | 10         | 12         | 3      | ¾      | 1¼             | 5460                     |
| SFSDH-72161 | 72   | 161 | 20½  | 120   | ¾            | 14        | 12         | 14         | 4      | ¾      | 1¼             | 8260                     |
| SFSDH-84167 | 84   | 167 | 23½  | 120   | 1            | 16        | 16         | 16         | 4      | ¾      | 1¼             | 10390                    |
| SFSDH-96173 | 96   | 173 | 26½  | 120   | 1            | 18        | 16         | 18         | 5      | ¾      | 1¼             | 14350                    |

All vessels are custom-built to customer specifications. Vessel dimensions and nozzle sizes in tables are suggestions for nominal conditions.

Oil Pots/Level Eye® Column

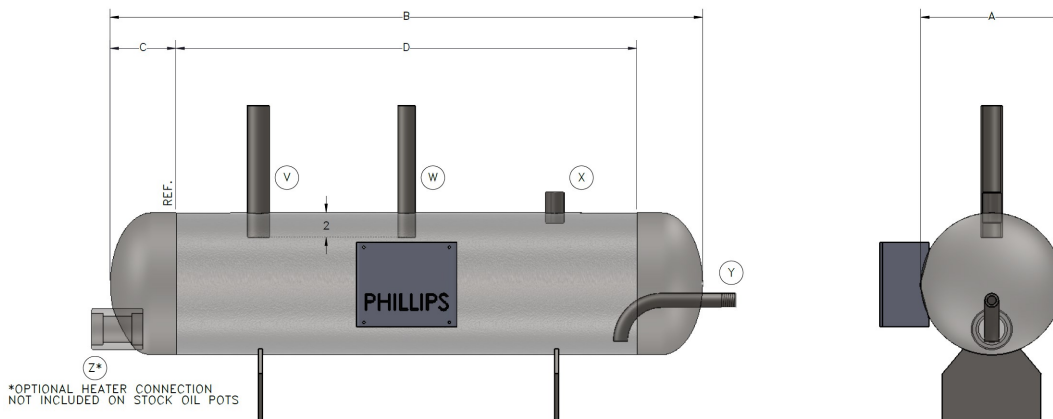

\*OPTIONAL HEATER CONNECTION  
NOT INCLUDED ON STOCK OIL POTS

|           | A    | B   | C    | D     | V     | W    | X      | Y     | Z       |                          |
|-----------|------|-----|------|-------|-------|------|--------|-------|---------|--------------------------|
| Model No. | Dia. | OAL | Head | Shell | Inlet | Vent | Relief | Drain | Heater* | Est. Shipping Wt. (lbs.) |
| 6P        | 6    | 36  | 3½   | 29    | 1     | ¾    | ½      | ½     | 1       | 70                       |
| 8P        | 8    | 36  | 4    | 28    | 1     | ¾    | ½      | ½     | 2       | 90                       |
| 10P       | 10   | 36  | 5    | 26    | 1¼    | ¾    | ½      | ½     | 2       | 110                      |
| 12P       | 12   | 36  | 5½   | 25    | 1½    | 1    | ½      | ½     | 2       | 130                      |

\*Optional heater connection - Not included on stock oil pots

Phillips stock oil pots

- 4 sizes of standard design oil pots, 6"x36", 8"x36", 10"x36", 12"x36"
- Stock oil pot nozzles are as shown in table above, less the heater coupling
- Standard rating is -50°F @ 400 PSI
- Sold in 3 trim levels, identified by the following suffix:
  - PA - Oil pot only
  - PB - Oil Pot with 250 PSI relief valve
  - PC - Oil pot with 250 PSI relief valve, inlet & vent globe valves, drain valve train including stop valve and spring-return valve
  - Example: 8" stock design oil pot with all accessories: 8PC

All vessels are custom-built to customer specifications. Vessel dimensions and nozzle sizes in tables are suggestions for nominal conditions

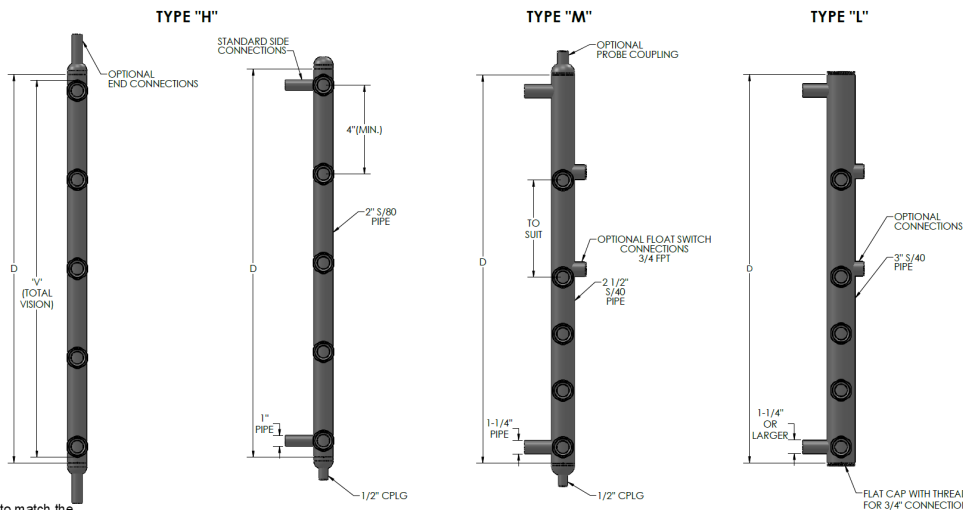

All columns are individually designed to match the Column Model Number:

|                       |   |   |       |
|-----------------------|---|---|-------|
| No. of Level Eyes®    | 6   | L | - 126 |
| Column Type:          | H<br>M<br>L                                     |   |       |
| Column Length, inches |   |   |       |
| Connection Location:  | (Blank): Side connections<br>E: End Connections |   |       |

Example: 6L-126: 3" diameter, 126" long, (6) Level Eyes®, side connections

Available options:

- Clear glass or reflex lens
- Frost shield or extended frost shield
- Stainless Steel Column/Level Eyes®
- Float switch connections (2 per set)
- Drain coupling
- 3/4" Level probe coupling

Specify options when ordering

| Type and Function:                   | Vessel range                   | Typical Setup   |
|--------------------------------------|--------------------------------|---|
| Type H: Made with 2" Sch 80 pipe     | High temperature (>80°F)       | Level Eye® spacing 6"-12", side connections to vessel, drain coupling   |
| Type M: Made with 2-1/2" Sch 40 pipe | Mid temperature (0°F - 125°F)  | Level Eye® spacing 6"-12", side connections to vessel, drain coupling, frost shields when temperature < 32°F      |
| Type L: Made with 3" Sch 40 pipe     | Low temperature (-40°F - 32°F) | (5) Level Eyes® with frost shield (extended frost shield for temperature < -20°F), (1) set float switch couplings |

# Vertical Pump Recirculator

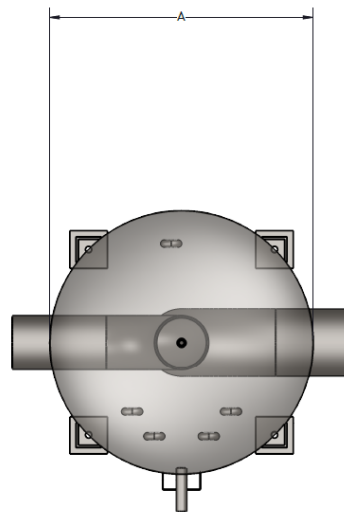
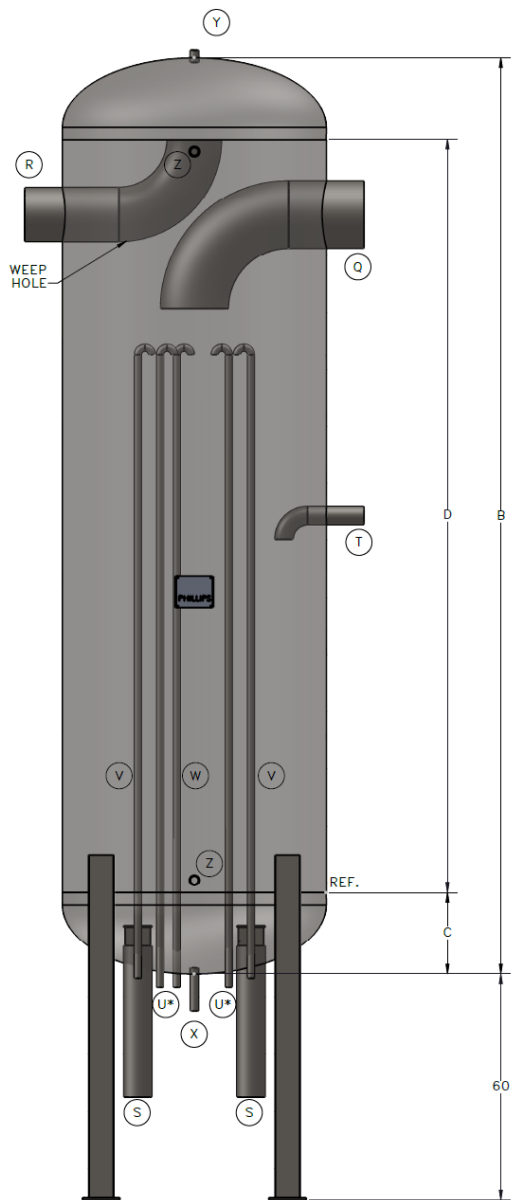

- (S) PUMP SUCTION W/  
VORTEX BREAKER
  - (U) MOTOR COOLANT  
RECIRC./PUMP VENT\*
  - (V) PUMP BYPASS
  - (W) OIL POT VENT
  - (X) DRAIN (TO OIL POT)
- \*USAGE DEPENDS ON  
PUMP TYPE

| Model No.  | A    | B   | C    | D     | Q             | R              | S            | T      | U                        | V                   | W            | X      | Y      | Z              | Est. Shipping Wt. (lbs.) |
|------------|------|-----|------|-------|---------------|----------------|--------------|--------|--------------------------|---------------------|--------------|--------|--------|----------------|--------------------------|
|            | Dia. | OAH | Head | Shell | Suction Inlet | Suction Outlet | Pump Suction | Makeup | Pump Vent/Recirc (Qty 2) | Pump Bypass (Qty 2) | Oil Pot Vent | Drain† | Relief | Column (Qty 2) |                          |
| RVV-24113  | 24   | 113 | 8½   | 96    | 6             | 5              | 4            | 1¼     | ¾                        | ¾                   | ¾            | 1      | ¾      | 1¼             | 1300                     |
| RVV-30116  | 30   | 116 | 10   | 96    | 8             | 6              | 4            | 1½     | ¾                        | ¾                   | ¾            | 1      | ¾      | 1¼             | 1700                     |
| RVV-36119  | 36   | 119 | 11½  | 96    | 8             | 6              | 4            | 2      | ¾                        | ¾                   | ¾            | 1      | ¾      | 1¼             | 2020                     |
| RVV-42146  | 42   | 146 | 13   | 120   | 10            | 8              | 4            | 2½     | ¾                        | ¾                   | ¾            | 1      | ¾      | 1¼             | 2880                     |
| RVV-48149  | 48   | 149 | 14½  | 120   | 10            | 10             | 4            | 2½     | ¾                        | ¾                   | ¾            | 1      | ¾      | 1¼             | 3330                     |
| RVV-54152  | 54   | 152 | 16   | 120   | 12            | 10             | 5            | 3      | ¾                        | ¾                   | ¾            | 1      | ¾      | 1¼             | 4800                     |
| RVV-60155  | 60   | 155 | 17½  | 120   | 12            | 12             | 5            | 3      | ¾                        | 1                   | ¾            | 1¼     | ¾      | 1¼             | 5520                     |
| RVV-72161  | 72   | 161 | 20½  | 120   | 16            | 14             | 6            | 4      | ¾                        | 1                   | ¾            | 1¼     | ¾      | 1¼             | 8600                     |
| RVV-84167  | 84   | 167 | 23½  | 120   | 18            | 16             | 8            | 5      | ¾                        | 1¼                  | 1            | 1½     | ¾      | 1¼             | 10610                    |
| RVV-96173  | 96   | 173 | 26½  | 120   | 20            | 18             | 8            | 5      | ¾                        | 1¼                  | 1            | 1½     | ¾      | 1¼             | 15220                    |
| RVV-108179 | 108  | 179 | 29½  | 120   | 20            | 20             | 10           | 6      | ¾                        | 1¼                  | 1            | 1½     | 1      | 1¼             | 20200                    |
| RVV-120185 | 120  | 185 | 32½  | 120   | 24            | 24             | 10           | 6      | ¾                        | 1½                  | 1            | 1½     | 1      | 1¼             | 26840                    |
| RVV-144197 | 144  | 197 | 38½  | 120   | 24            | 24             | 12           | 8      | ¾                        | 1½                  | 1            | 1½     | 1¼     | 1¼             | 39970                    |

†For temperatures below -20° oil drain size is 1-1/2"

All vessels are custom-built to customer specifications. Vessel dimensions and nozzle sizes in tables are suggestions for nominal conditions.

# Horizontal Pump Recirculator

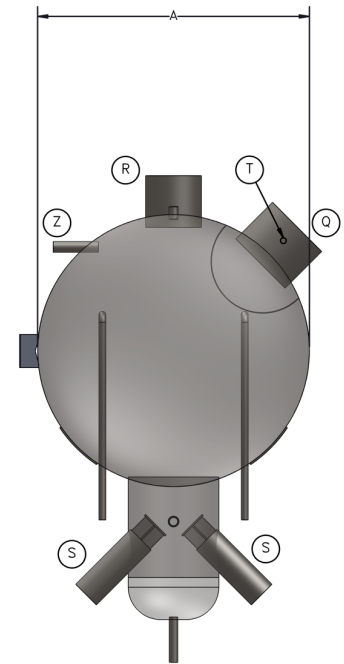
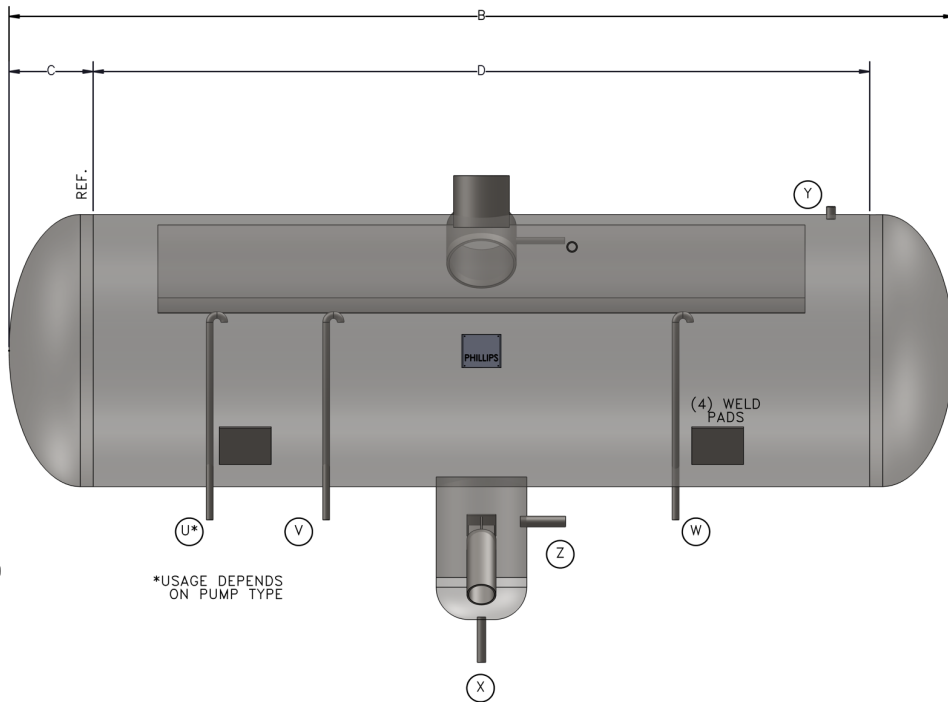

| Model No.  | A    | B   | C    | D     | I             | J             | Q             | R              | S            | T      | U                        | V                   | W            | X          | Y      | Z              | Est. Shipping Wt. (lbs.) |
|------------|------|-----|------|-------|---------------|---------------|---------------|----------------|--------------|--------|--------------------------|---------------------|--------------|------------|--------|----------------|--------------------------|
|            | Dia. | OAL | Head | Shell | Drop Leg Dia. | Drop Leg Len. | Suction Inlet | Suction Outlet | Pump Suction | Makeup | Pump Vent/Recirc (Qty 2) | Pump Bypass (Qty 2) | Oil Pot Vent | Oil Drain† | Relief | Column (Qty 2) |                          |
| RVH-24137  | 24   | 137 | 8½   | 120   | 8             | 12            | 6             | 5              | 4            | 1¼     | ¾                        | ¾                   | ¾            | 1          | ¾      | 1¼             | 1580                     |
| RVH-30140  | 30   | 140 | 10   | 120   | 10            | 12            | 8             | 6              | 4            | 1½     | ¾                        | ¾                   | ¾            | 1          | ¾      | 1¼             | 2020                     |
| RVH-36143  | 36   | 143 | 11½  | 102   | 12            | 12            | 8             | 6              | 4            | 1½     | ¾                        | ¾                   | ¾            | 1          | ¾      | 1¼             | 2370                     |
| RVH-42146  | 42   | 146 | 13   | 120   | 14            | 12            | 10            | 8              | 4            | 2      | ¾                        | ¾                   | ¾            | 1          | ¾      | 1¼             | 2880                     |
| RVH-48149  | 48   | 149 | 14½  | 120   | 14            | 12            | 10            | 8              | 4            | 2½     | ¾                        | ¾                   | ¾            | 1          | ¾      | 1¼             | 3260                     |
| RVH-54152  | 54   | 152 | 16   | 120   | 16            | 12            | 10            | 10             | 4            | 2½     | ¾                        | 1                   | ¾            | 1          | ¾      | 1¼             | 4660                     |
| RVH-60155  | 60   | 155 | 17½  | 120   | 4             | 12            | 12            | 10             | 5            | 3      | ¾                        | 1                   | ¾            | 1¼         | ¾      | 1¼             | 5300                     |
| RVH-72161  | 72   | 161 | 20½  | 120   | 4             | 12            | 14            | 12             | 6            | 4      | ¾                        | 1                   | ¾            | 1¼         | ¾      | 1¼             | 8020                     |
| RVH-84167  | 84   | 167 | 23½  | 120   | 4             | 12            | 16            | 16             | 8            | 4      | ¾                        | 1                   | 1            | 1½         | ¾      | 1¼             | 9840                     |
| RVH-96173  | 96   | 173 | 26½  | 120   | 4             | 12            | 18            | 16             | 8            | 5      | ¾                        | 1¼                  | 1            | 1½         | ¾      | 1¼             | 13290                    |
| RVH-108179 | 108  | 179 | 29½  | 120   | 4             | 12            | 20            | 18             | 8            | 5      | ¾                        | 1¼                  | 1            | 1½         | 1      | 1¼             | 18020                    |
| RVH-120185 | 120  | 185 | 32½  | 120   | 4             | 12            | 24            | 20             | 10           | 6      | ¾                        | 1½                  | 1            | 1½         | 1      | 1¼             | 23730                    |
| RVH-144197 | 144  | 197 | 38½  | 120   | 4             | 12            | 24            | 24             | 12           | 8      | ¾                        | 1½                  | 1            | 1½         | 1¼     | 1¼             | 36430                    |

†For temperatures below -20° oil drain size is 1-1/2"

All vessels are custom-built to customer specifications. Vessel dimensions and nozzle sizes in tables are suggestions for nominal conditions.

# Dry Oil Separator

The Phillips DOS models are simple, economical, low-pressure drop oil separators with permanent stainless steel wire mesh pads that effectively collect oil. These separators are well-suited for use with the Phillips 270A float valve for returning oil to the crankcase (or oil receiver).

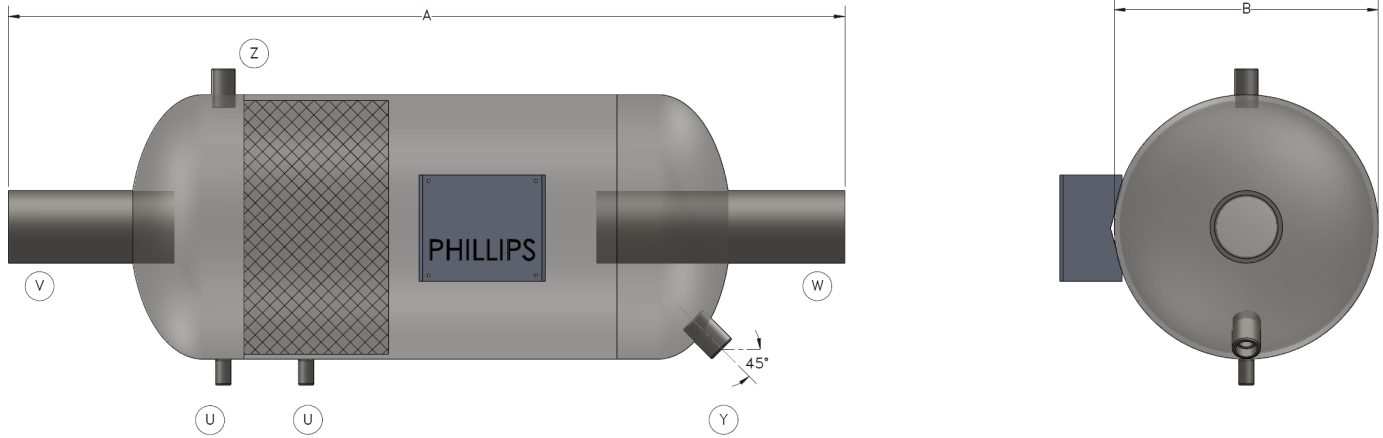

\*FLOAT VALVE SUPPORT ROD COUPLING (QTY. 1)  
LOCATION (HEAD OR SHELL) DEPENDS ON MODEL

| Model No.   | Nom Dia. | A                  | B           | U                   | V         | W         | Y     | Z      | ODC Inlet and Outlet (Optional) | Est. Shipping Wt. (lbs.) |
|-------------|----------|--------------------|-------------|---------------------|-----------|-----------|-------|--------|---------------------------------|--------------------------|
|             |          | Length (Pipe-Pipe) | Actual Dia. | Float Valve Support | Inlet (H) | Inlet (V) | Drain | Relief |                                 |                          |
| DOS--2½--¾  | 2½       | 16                 | 2.875       | ¼                   | ¾         | ¾         | ¾     | N/A    | -                               | 10                       |
| DOS--5--1¼  | 5        | 22                 | 5.563       | ¼                   | 1¼        | 1¼        | ¾     | ½      | 1⅝                              | 25                       |
| DOS--5--1½  | 5        | 22                 | 5.563       | ¼                   | 1½        | 1½        | ¾     | ½      | 1⅝                              | 25                       |
| DOS--6--1½  | 6        | 24                 | 6.625       | ¼                   | 1½        | 1½        | ¾     | ½      | 1⅝                              | 33                       |
| DOS--6--2   | 6        | 24                 | 6.625       | ¼                   | 2         | 2         | ¾     | ½      | 2⅝                              | 33                       |
| DOS--8--2   | 8        | 28.5               | 8.625       | ¼                   | 2         | 2         | ¾     | ½      | 2⅝                              | 44                       |
| DOS--8--2½  | 8        | 28.5               | 8.625       | ¼                   | 2½        | 2½        | ¾     | ½      | 2⅝                              | 44                       |
| DOS--10--2½ | 10       | 33                 | 10.75       | ¼                   | 2½        | 2½        | ¾     | ½      | 2⅝                              | 75                       |
| DOS--10--3  | 10       | 33                 | 10.75       | ¼                   | 3         | 3         | ¾     | ½      | 3⅝                              | 75                       |
| DOS--12--3  | 12       | 35                 | 12.75       | ¼                   | 3         | 3         | ¾     | ½      | 3⅝                              | 95                       |
| DOS--12--4  | 12       | 35                 | 12.75       | ¼                   | 4         | 4         | ¾     | ½      | 4⅝                              | 95                       |
| DOS--16--4  | 16       | 41                 | 16          | ¼                   | 4         | 4         | ¾     | ½      | -                               | 148                      |
| DOS--20--5  | 20       | 52                 | 20          | ¼                   | 5         | 5         | ¾     | ½      | -                               | 328                      |
| DOS--24--6  | 24       | 59                 | 24          | ¼                   | 6         | 6         | ¾     | ¾      | -                               | 466                      |
| DOS--30--8  | 30       | 72                 | 30          | ¼                   | 8         | 8         | ¾     | ¾      | -                               | 741                      |

\*Multiple nozzle sizes are offered on sizes 5-12 to allow for "in between" selections or when oversized bodies are preferred.

\*\*Piping components available with DOSKIT (minus float valve)

| Model     | SWEPT VOLUME DISPLACEMENT, CFM |               |              |               |
|-----------|--------------------------------|---------------|--------------|---------------|
|           | Ammonia                        |               | R-22         |               |
|           | Single Stage                   | Booster Stage | Single Stage | Booster Stage |
| DOS-2½-¾  | 18                             | 36            | 8            | 12            |
| DOS-3½-1¼ | 39                             | 78            | 16           | 26            |
| DOS-5-1¼  | 81                             | 162           | 32           | 54            |
| DOS-5-1½  | 81                             | 162           | 32           | 54            |
| DOS-6-1½  | 117                            | 234           | 47           | 78            |
| DOS-6-2   | 117                            | 234           | 47           | 78            |
| DOS-8-2   | 210                            | 420           | 84           | 140           |
| DOS-8-2½  | 210                            | 420           | 84           | 140           |
| DOS-10-2½ | 333                            | 666           | 133          | 222           |
| DOS-10-3  | 333                            | 666           | 133          | 222           |
| DOS-12-3  | 480                            | 960           | 190          | 320           |
| DOS-12-4  | 480                            | 960           | 190          | 320           |
| DOS-16-4  | 750                            | 1500          | 300          | 500           |
| DOS-20-5  | 1175                           | 2350          | 470          | 780           |
| DOS-24-6  | 1715                           | 3430          | 686          | 1143          |
| DOS-30-8  | 3050                           | 6100          | 1220         | 2040          |

\*Multiple nozzle sizes are offered on sizes 5-12 to allow for "in between" selections or when oversized bodies are preferred.

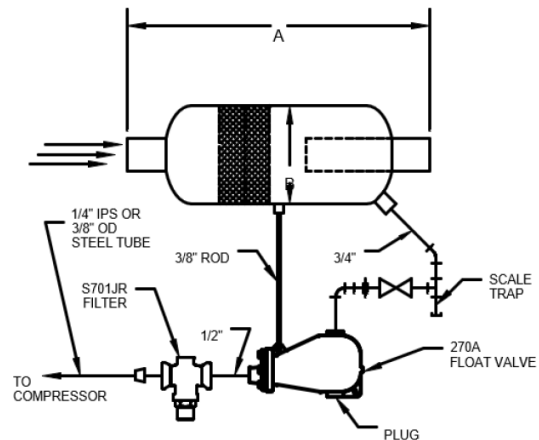

Vessel with DOSKIT\*\* and float valve

All vessels are custom-built to customer specifications. Vessel dimensions and nozzle sizes in tables are suggestions for nominal conditions.

# Coalescent Oil Separator

The Phillips COS models offer increased filtration capabilities through the dual use of stainless steel wire mesh pads and replaceable coalescing elements.

- \* Design allows for inspection and replacement of coalescing elements.
- \* For vessels up to 20" diameter, access is through a blind flange. For vessels 24" and larger, access is through a manway.
- \* Quantity and model of coalescent element is highly dependent on operating conditions. When requesting quote, please provide:
  - Swept Volume (displacement) of compressor
  - Suction Temperature
  - Discharge Pressure

**HIGH STAGE COS RATINGS**

| Model   | SWEPT VOLUME DISPLACEMENT (CFM), +95°F CONDENSING |       |       |       |       |       |
|---------|---|-------|-------|-------|-------|-------|
|         | +10°F   | +15°F | +20°F | +25°F | +30°F | +35°F |
| COS10AH | 198   | 178   | 160   | 144   | 131   | 118   |
| COS12AH | 284   | 255   | 230   | 208   | 188   | 170   |
| COS16AH | 457   | 411   | 370   | 334   | 302   | 274   |
| COS20AH | 723   | 650   | 585   | 528   | 477   | 433   |
| COS24AH | 1032  | 927   | 835   | 754   | 681   | 618   |
| COS30AH | 1632  | 1466  | 1320  | 1191  | 1077  | 976   |
| COS36AH | 2373  | 2132  | 1920  | 1733  | 1567  | 1420  |
| COS42AH | 3251  | 2921  | 2630  | 2374  | 2146  | 1945  |
| COS48AH | 4215  | 3787  | 3410  | 3077  | 2783  | 2522  |

**LOW STAGE COS RATINGS**

| Model   | SWEPT VOLUME DISPLACEMENT (CFM), +10°F CONDENSING |       |       |       |       |       |
|---------|---|-------|-------|-------|-------|-------|
|         | -45°F   | -40°F | -35°F | -30°F | -25°F | -20°F |
| COS10AL | 211   | 184   | 160   | 140   | 123   | 108   |
| COS12AL | 304   | 264   | 230   | 201   | 177   | 156   |
| COS16AL | 489   | 424   | 370   | 324   | 284   | 250   |
| COS20AL | 772   | 671   | 585   | 512   | 449   | 396   |
| COS24AL | 1103  | 958   | 835   | 731   | 642   | 565   |
| COS30AL | 1743  | 1514  | 1320  | 1155  | 1014  | 893   |
| COS36AL | 2535  | 2202  | 1920  | 1680  | 1475  | 1300  |
| COS42AL | 3473  | 3016  | 2630  | 2301  | 2021  | 1780  |
| COS48AL | 4502  | 3911  | 3410  | 2984  | 2620  | 2308  |

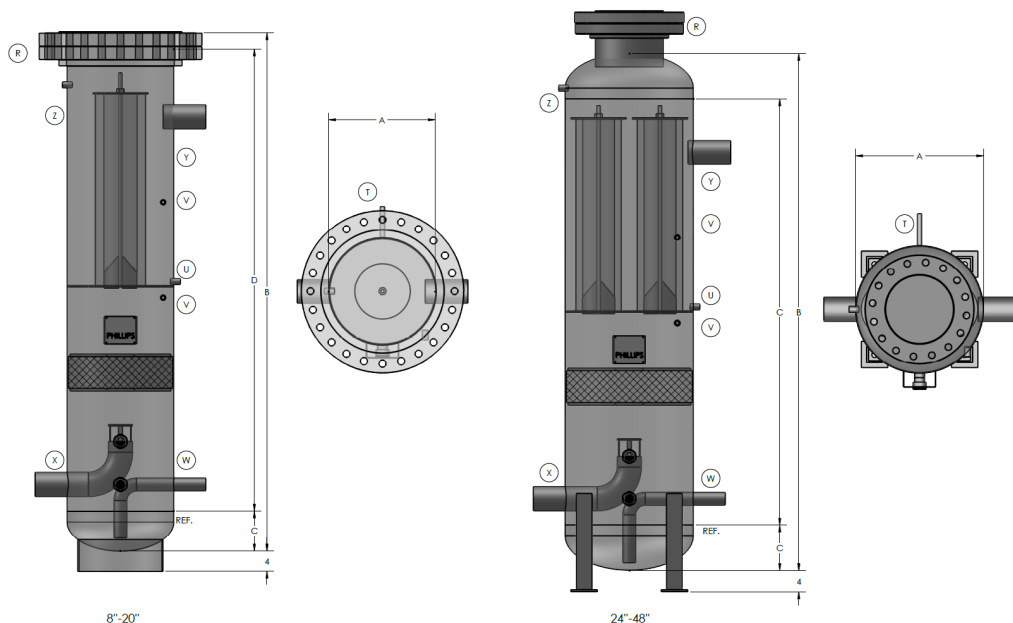

**COALESCENT OIL SEPARATOR DIMENSIONS**

| Model No.  | A    | B   | C    | D     | R             | T       | U     | V      | W            | X          | Y     | Z      | Est. Shipping Wt. (lbs.) |                          |
|------------|------|-----|------|-------|---------------|---------|-------|--------|--------------|------------|-------|--------|--------------------------|--------------------------|
| Model No.  | Dia. | OAH | Head | Shell | Level Eye (2) | Flange* | Drain | Drain2 | Instrmnt (2) | Oil Outlet | Inlet | Outlet | Relief                   | Est. Shipping Wt. (lbs.) |
| COS10AH/AL | 10   | 65  | 5    | 60    | 1100A-R       | 10      | ½     | ½      | ½            | 1          | 2     | 2      | ½                        | 440                      |
| COS12AH/AL | 12   | 65½ | 5½   | 60    | 1100A-R       | 12      | ½     | ½      | ½            | 1½         | 3     | 3      | ½                        | 590                      |
| COS16AH/AL | 16   | 78½ | 6½   | 72    | 1100A-R       | 16      | ½     | ½      | ½            | 1½         | 4     | 4      | ½                        | 960                      |
| COS20AH/AL | 20   | 79½ | 7½   | 72    | 1100A-R       | 20      | ½     | ½      | ½            | 2          | 5     | 5      | ¾                        | 1390                     |
| COS24AH/AL | 24   | 101 | 8½   | 84    | 1100A-R       | 12      | ½     | ½      | ½            | 2          | 6     | 6      | ¾                        | 1200                     |
| COS30AH/AL | 30   | 116 | 10   | 96    | 1100A-R       | 14      | ½     | ½      | ½            | 2½         | 8     | 8      | ¾                        | 1750                     |
| COS36AH/AL | 36   | 119 | 11½  | 96    | 1100A-R       | 18      | ½     | ½      | ½            | 3          | 10    | 10     | ¾                        | 2310                     |
| COS42AH/AL | 42   | 146 | 13   | 120   | 1100A-R       | 20      | ½     | ½      | ½            | 4          | 10    | 10     | ¾                        | 3210                     |
| COS48AH/AL | 48   | 149 | 14½  | 120   | 1100A-R       | 24      | ½     | ½      | ½            | 5          | 12    | 12     | ¾                        | 3880                     |

All dimensions are in inches  
\*Flange size subject to change based on coalescing element selection

All vessels are custom-built to customer specifications. Vessel dimensions and nozzle sizes in tables are suggestions for nominal conditions.

# Anhydrator System Cleaner

The Anhydrator removes water and other impurities from your ammonia refrigeration system. If left in your system, these impurities can cause inefficient operation, clogging of strainers, corrosion and premature failure of compressor bearings.

If your air purger is venting air, it is leaving behind the moisture that entered the system with the air. Since water is condensable, it is not removed by the purger. Rather, it seeks the lowest temperature location in the system. That's where it can be removed.

Aside from being a great preventative maintenance tool, the payback can be quite fast. Each percent of water in the ammonia is equal to a 1% drop in compressor efficiency. Put another way, water increases the temperature - pressure relationship of the mixture, causing the compressor to work harder to maintain the same temperature. A clean refrigeration system uses much less energy - that translates into savings.

Trim levels:

- ANH: Bare Anhydrator vessel
- ANH-CV: Anhydrator vessel with valve group shipped loose
- ANH-CV-A: Anhydrator vessel with valve group shipped factory installed (relief, liquid feed stop valve, and strainer ship loose)

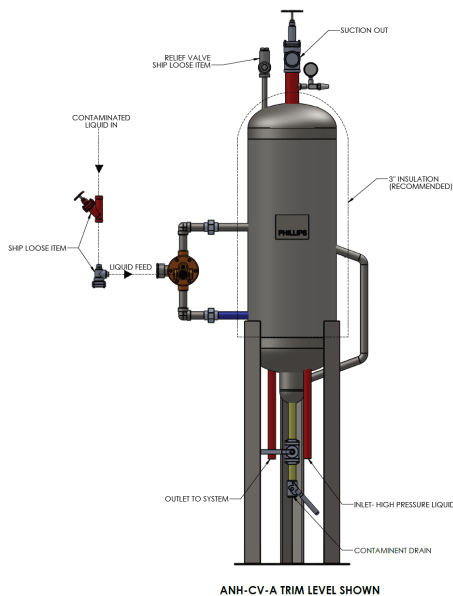

Liquid feed

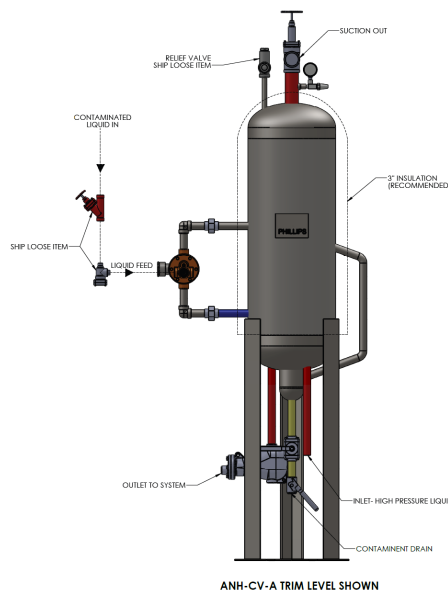

Hot gas feed  
(shown with 270A valve - purchased separately)

- Valve Group Includes:
- Phillips float valve (300HM-GZB)
  - Liquid in isolation valve
  - Liquid in strainer
  - Relief valve
  - Suction stop valve
  - Gauge and gauge valve
  - 1" Ball drain valve
  - Spring return secondary drain

Also available: 100ml lab-grade moisture sampling container, part number ANH-MS  
Moisture sampling test stand, part number ANH-AS

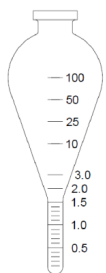

- ANH-MS Sampling Container

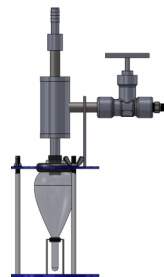

STAND, CHAMBER, NEEDLE VALVE, ANH-MS INCLUDED IN PLASTIC CASE

- ANH-AS Sampling Stand Kit



PUR & PURJR Air Purger

The Phillips PUR Air Purger is a simple, robust, high-capacity device that removes non-condensable gases from the refrigerant vapor in a system. The unit operates by condensing foul gas (the mixture of refrigerant vapor and non-condensables) from one or more purge points, metering the purified liquid refrigerant back to the system through a protected suction connection, and venting the non-condensables to atmosphere.

The single size model PUR will effectively purge non-condensables from any sized refrigeration system and works with all typical refrigerants.

The smaller PURJR is designed to operate single condenser systems.

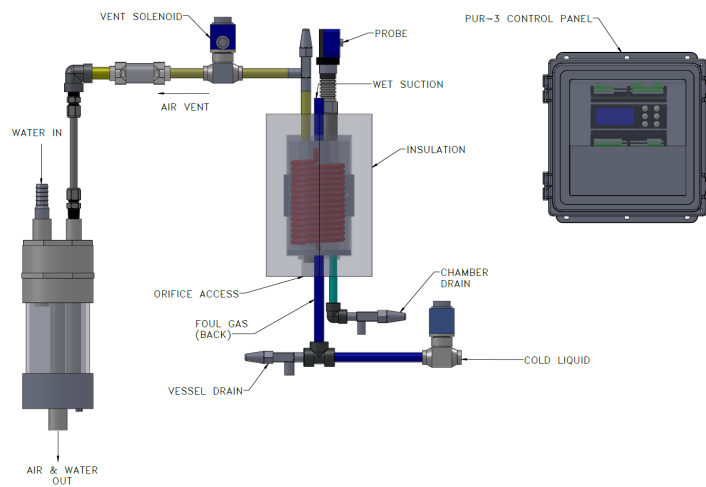
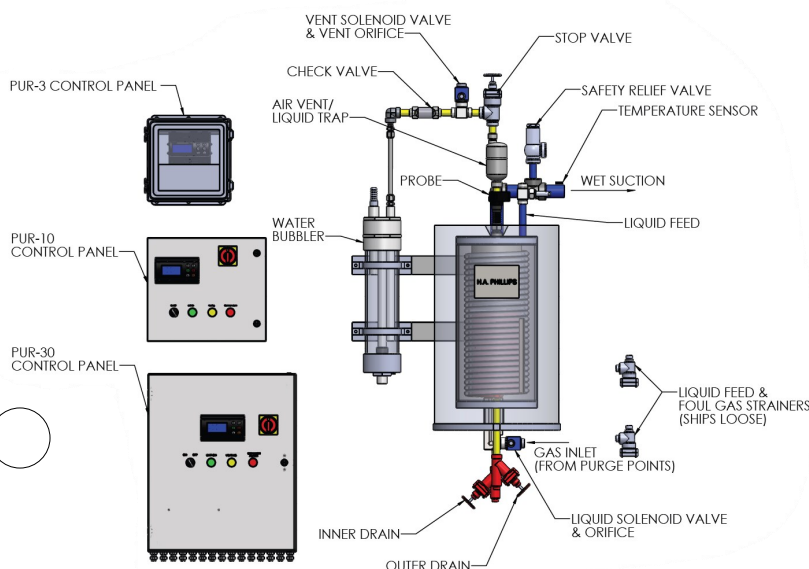

The PUR Air Purger ships bracket mounted and insulated with the following available options:

- Bubbler
- 3, 10, or 30-point control panel

The PURJR Air Purger ships with factory insulation, bubbler, and 3-point controller included.

When ordering, please specify desired trim level:

- PUR-I: Purger with valves and Insulation
- PUR-BI: Purger with valves, bubbler and insulation
- PUR-IP: Purger with valves, insulation and 3-point control panel
- PUR-BIP: Purger with valves, bubbler, insulation, and 3-point control panel
- Purge point expansion module ordered at time of purchase depending on system requirements

## Gas Driven Recirculating Systems

Phillips Type DR Gas Driven Recirculating systems overfeed evaporators with partially subcooled liquid without the use of mechanical pumps, while also providing slop-over protection for the compressors. Furthermore, with a properly designed CPR vessel, DR systems can also be used in both stages of a 2-stage system, or can also be used to circulate totally subcooled liquid.

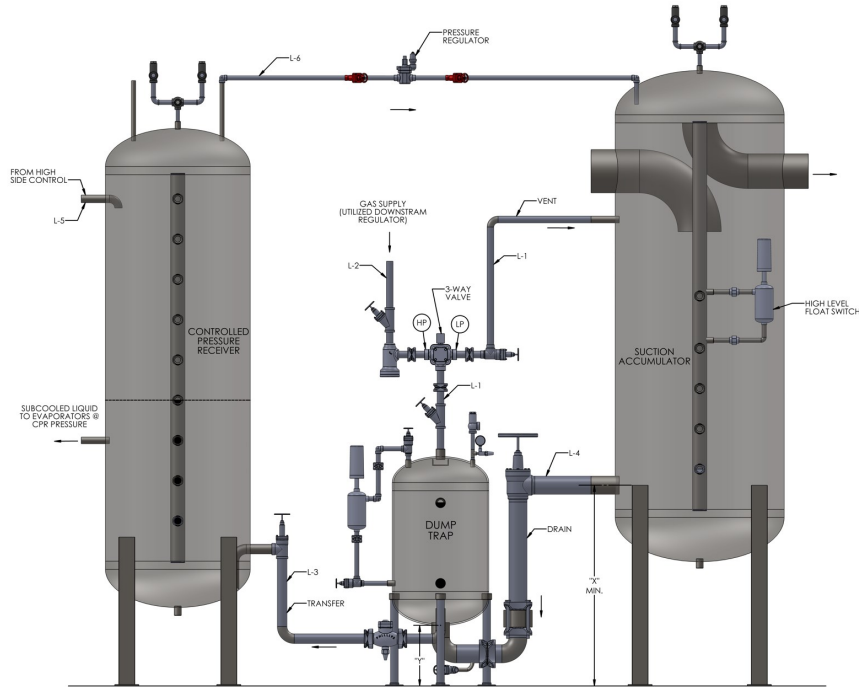

Typical GDRS System Layout  
(Vertical Dump Trap shown)

### VERTICAL DUMP TRAP SYSTEMS-AMMONIA

| LIQUID RETURN UNIT CAT. NO. | TOTAL TONS AT ACCUMULATOR | LIQUID RETURN CAPACITY (GPM) | DUMP TRAP SIZE (D. X HT.) (IN.) | MIN. DRAIN HEIGHT 'X' REQ'D (IN.) | DIM. 'Y' (IN.) | LINE SIZES (IPS-IN.) |                  |                |                     | SHIPPING WEIGHT (LBS.) |
|-----------------------------|---------------------------|------------------------------|---------------------------------|-----------------------------------|----------------|----------------------|------------------|----------------|---------------------|------------------------|
|                             |                           |                              |                                 |                                   |                | L-1 (TRAP) (VENT)    | L-2 (GAS) SUPPLY | L-3 (TRANSFER) | L-4 DRAIN (TO TRAP) |                        |
| DR40V                       | 40                        | 7                            | 12 X 26                         | 30                                | 10             | 3/4                  | 3/4              | 3/4            | 1 1/2               | 275                    |
| DR75V                       | 75                        | 14                           | 16 X 38                         | 40                                | 11             | 3/4                  | 3/4              | 1 1/4          | 2                   | 400                    |
| DR100V                      | 100                       | 18                           | 18 X 38                         | 44                                | 12             | 1 1/4                | 1 1/4            | 1 1/4          | 2 1/2               | 585                    |
| DR150V                      | 150                       | 28                           | 20 X 40                         | 46                                | 13             | 1 1/4                | 1 1/4            | 1 1/2          | 3                   | 630                    |
| DR260V                      | 260                       | 48                           | 24 X 42                         | 47                                | 16             | 1 1/4                | 1 1/4            | 2              | 4                   | 780                    |
| DR520V                      | 520                       | 98                           | 30 X 54                         | 66                                | 18             | 2                    | 1 1/4            | 3              | 4 (2)               | 1630                   |
| DR920V                      | 920                       | 190                          | 42 X 60                         | 78                                | 24             | 3                    | 1 1/2            | 3              | 4 (3)               | 1875                   |

### HORIZONTAL DUMP TRAP SYSTEMS-AMMONIA

| LIQUID RETURN UNIT CAT. NO. | TOTAL TONS AT ACCUMULATOR | LIQUID RETURN CAPACITY (GPM) | DUMP TRAP SIZE (D. X HT.) (IN.) | MIN. DRAIN HEIGHT 'X' REQ'D (IN.) | DIM. 'Y' (IN.) | LINE SIZES (IPS-IN.) |                  |                |                     | SHIPPING WEIGHT (LBS.) |
|-----------------------------|---------------------------|------------------------------|---------------------------------|-----------------------------------|----------------|----------------------|------------------|----------------|---------------------|------------------------|
|                             |                           |                              |                                 |                                   |                | L-1 (TRAP) (VENT)    | L-2 (GAS) SUPPLY | L-3 (TRANSFER) | L-4 DRAIN (TO TRAP) |                        |
| DR40H                       | 40                        | 7                            | 12 X 26                         | 25                                | 10             | 3/4                  | 3/4              | 3/4            | 1 1/2               | 275                    |
| DR75H                       | 75                        | 14                           | 16 X 38                         | 30                                | 11             | 3/4                  | 3/4              | 1 1/4          | 2                   | 400                    |
| DR100H                      | 100                       | 18                           | 18 X 38                         | 27                                | 12             | 1 1/4                | 1 1/4            | 1 1/4          | 2 1/2               | 585                    |
| DR150H                      | 150                       | 28                           | 20 X 40                         | 35                                | 13             | 1 1/4                | 1 1/4            | 1 1/2          | 3                   | 630                    |
| DR260H                      | 260                       | 48                           | 24 X 42                         | 42                                | 16             | 1 1/4                | 1 1/4            | 2              | 4                   | 780                    |
| DR520H                      | 520                       | 98                           | 24 X 84                         | 42                                | 16             | 2                    | 1 1/4            | 3              | 4 (2)               | 1830                   |
| DR920H                      | 920                       | 190                          | 30 X 115                        | 45                                | 18             | 3                    | 1 1/2            | 4              | 4 (3)               | 2110                   |

## Gas Driven Recirculating Systems

ITEMS SUPPLIED WITH STANDARD DR SYSTEMS:

**Dump Trap:** Pressure vessel rated for -50°F and 300 PSI, "U" stamped and National Board registered

**3-Way Valve:** Phillips Series 3000 solenoid-operated 3-way valve, with angle filter (other valve arrangements available for very large systems)

**Level Control:** External float switch (initiates transfer cycle)

**Accessories:** Level Eyes®, gauge and gauge valve, relief valve, unions, floor flanges (vertical traps)

**Control Panel:** UL/NEMA4 enclosure with adjustable timer, manual transfer switch, mounted cycle counter, alarm selector switch and pilot light indicators.

**LINE L-1:** Stop valves and unions

**LINE L-2:** Stop valves, downstream regulator, filter/strainer and union

**LINE L-3:** Stop valve, outlet check valve

**LINE L-4:** Stop valve, inlet check valve, union, drain valve

OPTIONAL RC HIGH SIDE CONTROL (WITH OR WITHOUT PILOT RECEIVER)

| PLANT SIZE (TONS) | L-5 SIZE (IN.) | L-6 SIZE (IN.) | WITHOUT PILOT RCVR |                   | WITH PILOT RCVR |                   |                   |
|-------------------|----------------|----------------|--------------------|-------------------|-----------------|-------------------|-------------------|
|                   |                |                | MODEL              | SHIPPING WT (LBS) | MODEL           | PILOT RCVR MODEL* | SHIPPING WT (LBS) |
| 80                | 3/4            | 3/4            | RC075              | 130               | RC075PR         | PRV-1248B         | 280               |
| 160               | 1              | 3/4            | RC100              | 145               | RC100PR         | PRV-1248C         | 295               |
| 250               | 1-1/4          | 3/4            | RC125              | 190               | RC125PR         | PRV-1248D         | 340               |
| 400               | 1-1/2          | 3/4            | RC150              | 240               | RC150PR         | PRV-1248E         | 390               |
| 800               | 2              | 1-1/4          | RC200              | 310               | RC200PR         | PRV-1248F         | 460               |
| 1250              | 2-1/2          | 1-1/2          | RC250              | 490               | RC250PR         | PRV-1648A         | 730               |
| 2000              | 3              | 2              | RC300              | 560               | RC300PR         | PRV-1648B         | 800               |
| 3000              | 4              | 2-1/2          | RC400              | 740               | RC400PR         | PRV-2060A         | 1280              |

\* Refer to page 8 for further description of Pilot Receiver

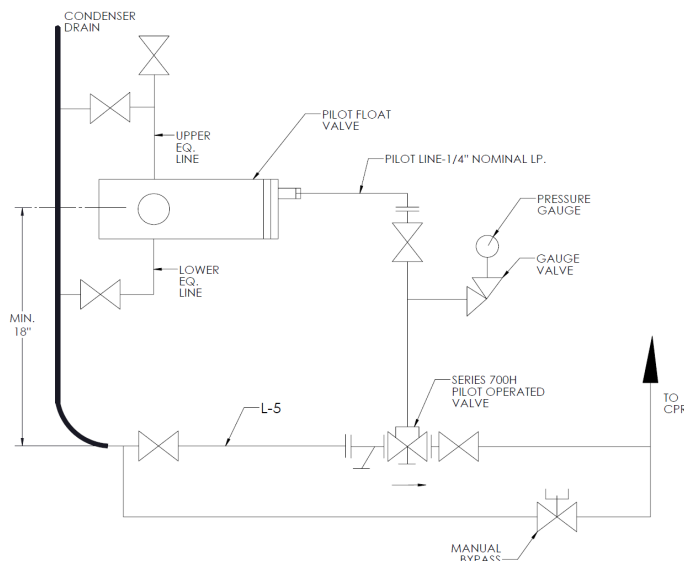

Typical High Side Control Schematic

ITEMS SUPPLIED WITH RC HIGH SIDE CONTROL SYSTEMS:

- Series 275AP pilot float valve and steel float chamber with Level Eye® sight glass
- (2) 3/4" Service valves for pilot float valve chamber
- 3/4" vent valve for pilot float valve chamber
- Pilot line kit including gauge valve, gauge, 1/4" service valve, union and 1/2" x 1/4" bushing
- **LINE L-5:** Series 700H high side pilot-operated main valve with strainer, (2) isolation valves and hand expansion bypass valve
- **Line L-6:** Pressure regulator with (2) isolation valves

## Compressor Protection Systems

Phillips compressor protection systems economically transfer accumulated liquid from the low side of the system to the high side where the liquid can be re-used without unnecessary phase changes.

### SYSTEM TYPES AND DESCRIPTIONS

**Type T:** For transferring liquid to a CPR or other intermediate pressure vessel. This system requires the target vessel to be at least 10PSI lower than compressor discharge pressure. A regulator should be used upstream of the 3-way valve to control inlet pressure just high enough to make the transfer.

**Type A:** For transferring liquid to a HPR when the suction accumulator is at a higher elevation than the HPR.

**Type DK:** For transferring liquid to a HPR with the assistance of an interrupting valve that maintains a pressure difference between the dump trap and the HPR.

**Type G:** For transferring liquid to a HPR with the assistance of a mechanical pump.

### SYSTEM COMPONENTS

**Dump Trap:** Pressure vessel rated for -50°F and 300 PSI, stamped and National Board registered

**3-Way Valve:** Phillips Series 3000 solenoid-operated 3-way valve, with angle filter (other valve arrangements available for very large systems)

**Check Valves:** Phillips Series 600 and 700 flanged in-line disc and piston type check valves as indicated in piping schematics

**Service Valves:** Hand stop valves as indicated in system piping schematics

**Level Control:** External float switch (initiates transfer cycle)

**Accessories:** Level Eyes®, gauge and gauge valve, relief valve, unions, floor flanges (vertical traps)

**Control Panel:** UL/NEMA4 enclosure with adjustable timer(s), manual transfer switch, mounted cycle counter, alarm selector switch and pilot light indicators.

### ADDITIONAL ITEMS FOR TYPE G SYSTEMS:

**Pump:** Nikkiso or Teikoku sealless liquid refrigerant pump is standard. Corken centrifugal and magnetic drive pumps available as options.

**Pump Relief:** A check valve is placed in the bypass line going back to the pump suction to prevent deadheading

### SEQUENCE OF OPERATIONS

For all types of transfer system, the transfer cycle is initiated when the liquid draining from the suction accumulator reaches the middle of the upper Level Eye on the dump trap. This signal energizes the 3-way valve changing its operation from vent to hot gas supply. Liquid is then transferred according to system type:

**TYPE T:** As liquid starts to transfer, the level in the trap drops causing the float switch to open. This starts the adjustable off-delay cycle timer. When the cycle times out, the 3-way valve de-energizes and allows the trap to vent back to the accumulator. The timer should be set so that all liquid is drained past the outlet check valve.

**TYPE A:** As liquid starts to transfer, the level in the trap drops causing the float switch to open. This starts the adjustable off-delay cycle timer. When the cycle times out, the 3-way valve de-energizes and allows the trap to vent back to the accumulator. The timer should be set so that all liquid is drained past the hand valve at the HPR.

**TYPE DK:** When the 3-way valve is energized so is the interrupting valve, causing it to change from wide open to differential pressure control. Since the pressure in the hot gas line to the trap is higher than the HPR pressure, the liquid will start to flow out of the trap, causing the float switch to open. This starts the adjustable off-delay cycle timer. When the cycle times out, the 3-way valve de-energizes, allowing the trap to vent back to the accumulator and the interrupting valve is de-energized. The timer should be set to drain the liquid completely past the outlet check valve.

**TYPE G:** The float switch actuation also starts 2 adjustable on-delay relays, one for the pump and one for pump protection. When the pump on-delay timer times out, the pump starts and the transfer begins. As liquid starts to transfer, the level in the trap drops causing the float switch to open. This starts the adjustable off-delay cycle timer. When the cycle timer times out, the pump stops and the 3-way valve is de-energized, allowing the trap to vent back to the accumulator. The pump on-delay timer must be set to allow time for the trap to become fully pressurized before the pump starts. The off-delay timer should be set to time out when the liquid level reaches the lower Level Eye (take care to never let the pump run dry). The pump protection on-delay timer should be set 10-15 seconds longer than the complete cycle and is meant to stop the pump if the float switch ever sticks open.

### INSTALLATION HINTS

- ALWAYS mount the inlet check valve as low and close to the dump trap as possible.
- On Type A systems, mount the outlet check valve vertically as close to the HPR as possible.
- Disc type checks should be mounted in the vertical orientation unless it is absolutely necessary to mount horizontally.
- Piston type checks can be mounted in either orientation but horizontal is preferred. It should be mounted below the lower Level Eye® on the trap.
- Mount float switch to engage at upper Level Eye®
- Insulate the dump trap; do not insulate the check valves
- Take care to set the timers properly. Adjust the timers as necessary whenever the refrigeration system operating parameters change.

Type T - Compressor Protection System

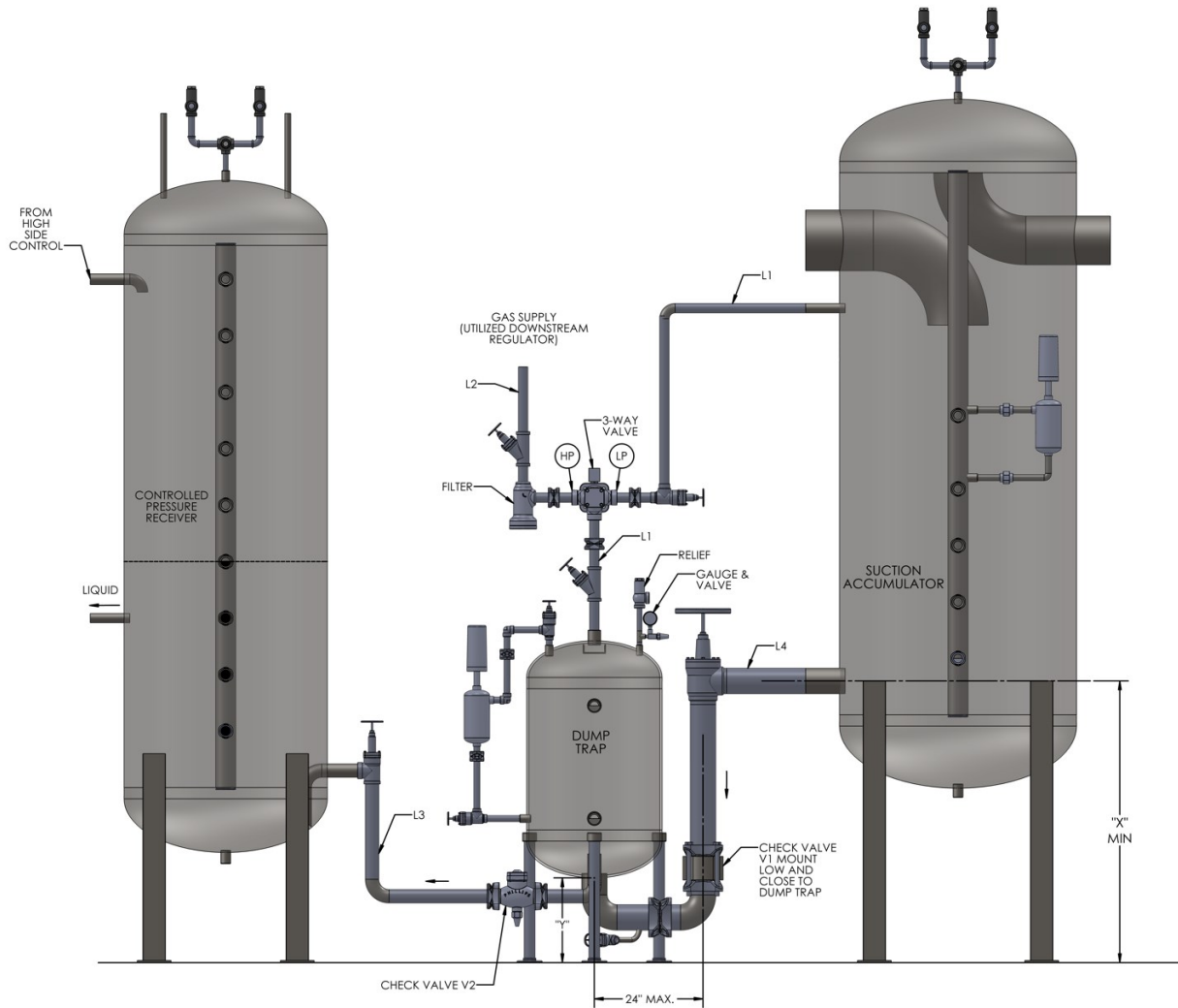

| CATALOG NUMBER* | ACCUM. CAP (TONS) | SYSTEM CAPACITY (GPM) | DUMP TRAP DIA x LNG (IN.) | "X" (MIN REQ'D, IN.) |      | "Y" (REF.) (IN.) | IPS LINE SIZES |        |             |          | SHIPPING WEIGHT (LBS.) |
|-----------------|-------------------|-----------------------|---------------------------|----------------------|------|------------------|----------------|--------|-------------|----------|------------------------|
|                 |                   |                       |                           | VERT.                | HOR. |                  | L1 VENT        | L2 GAS | L3 TRANSFER | L4 DRAIN |                        |
| T187V/H**       | 140               | 3.7                   | 12 x 26                   | 30                   | 25   | 10               | 3/4            | 3/4    | 3/4         | 1 1/4    | 270                    |
| T287V/H         | 240               | 6.1                   | 12 x 26                   | 30                   | 25   | 10               | 3/4            | 3/4    | 3/4         | 1 1/2    | 285                    |
| T387V/H         | 440               | 10.9                  | 16 x 38                   | 40                   | 30   | 11               | 3/4            | 3/4    | 1 1/4       | 2        | 430                    |
| T487V/H         | 760               | 19.1                  | 20 x 40                   | 46                   | 35   | 13               | 1 1/4          | 1 1/4  | 1 1/4       | 3        | 670                    |
| T587V/H         | 1480              | 31.2                  | 24 x 42                   | 47                   | 42   | 16               | 1 1/4          | 1 1/4  | 2           | 4        | 810                    |
| T687H           | 2000              | 56.5                  | 24 x 72                   | SP.                  | 42   | 16               | 1 1/4          | 1 1/4  | 3           | 4        | 1180                   |
| T787H           | 3000              | 73.4                  | 24 x 84                   | SP.                  | 42   | 16               | 2              | 1 1/4  | 3           | 4 (2)    | 1630                   |

**Ordering Instructions:**

\* When ordering, specify suffix "V" (for vertical dump trap) or suffix "H" (for horizontal dump trap).

\*\* Do not use 187 size systems when accumulator suction temperature is below 0°F. Upsize to 287 system.

If system is to be used for Halocarbon refrigerant, use 1/4 of the tonnage ratings shown for R-717. Add an "F" in front of the Catalog Number. Seal cap valves and accessories will be furnished.

Type A - Compressor Protection System

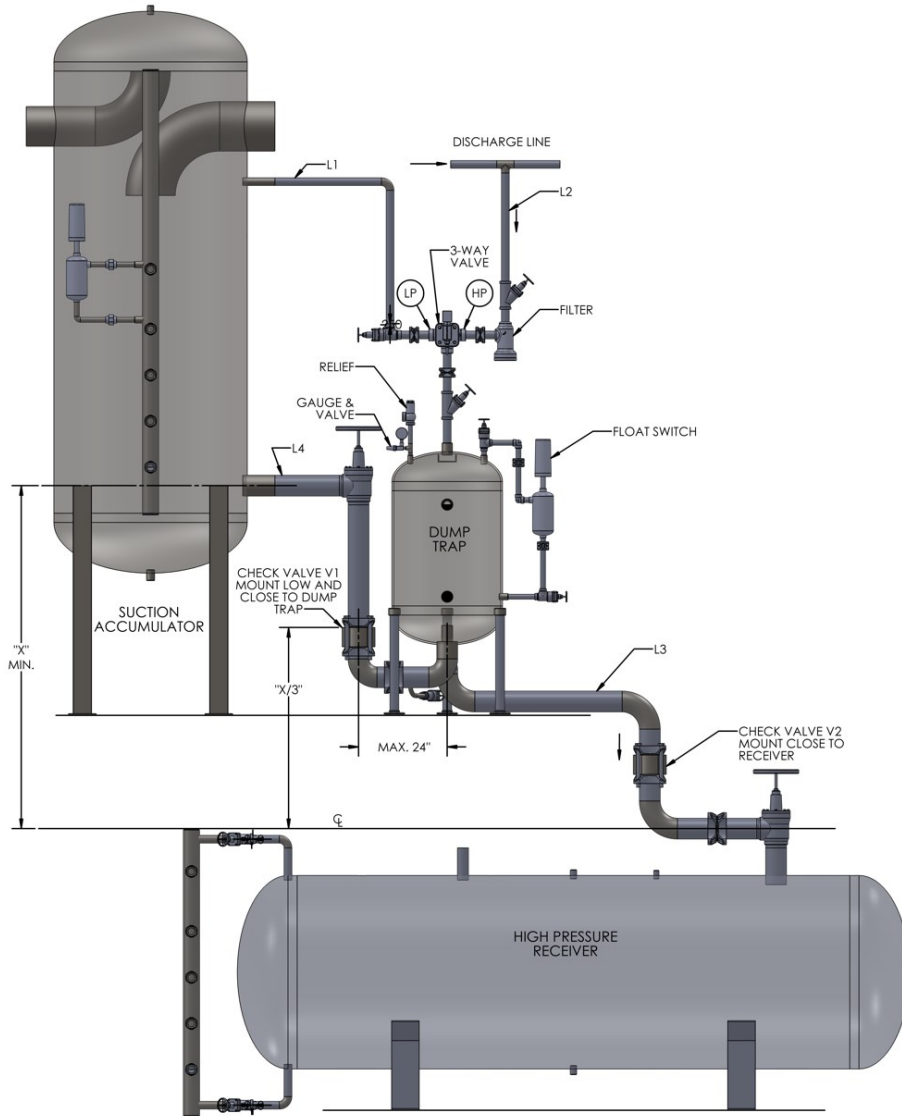

| CATALOG NUMBER* | ACCUM. CAP (TONS) | SYSTEM CAPACITY (GPM) | DUMP TRAP DIA x LNG (IN.) | "X" (MIN REQ'D) (IN.) |      | IPS LINE SIZES |               |             |          | SHIPPING WEIGHT (LBS.) |
|-----------------|-------------------|-----------------------|---------------------------|-----------------------|------|----------------|---------------|-------------|----------|------------------------|
|                 |                   |                       |                           | VERT.                 | HOR. | L1 VENT        | L2 GAS SUPPLY | L3 TRANSFER | L4 DRAIN |                        |
| A187V/H**       | 100               | 2.7                   | 12 x 26                   | 38                    | 28   | 3/4            | 3/4           | 1 1/4       | 1 1/4    | 270                    |
| A287V/H         | 200               | 6.7                   | 12 x 26                   | 40                    | 30   | 3/4            | 3/4           | 1 1/2       | 1 1/2    | 285                    |
| A387V/H         | 300               | 7.5                   | 16 x 38                   | 55                    | 36   | 3/4            | 3/4           | 2           | 2        | 450                    |
| A487V/H         | 800               | 20.2                  | 20 x 40                   | 62                    | 45   | 1 1/4          | 1 1/4         | 3           | 3        | 700                    |
| A587V/H         | 1320              | 33.3                  | 24 x 42                   | 70                    | 55   | 1 1/4          | 1 1/4         | 4           | 4        | 850                    |

**Ordering Instructions:**

\* When ordering, specify suffix "V" (for vertical dump trap) or suffix "H" (for horizontal dump trap).

\*\* Do not use 187 size systems when accumulator suction temperature is below 0°F. Upsize to 287 system.

If system is to be used for Halocarbon refrigerant, use 1/4 of the tonnage ratings shown for R-717. Add an "F" in front of the Catalog Number. Seal cap valves and accessories will be furnished.

Type DK - Compressor Protection System

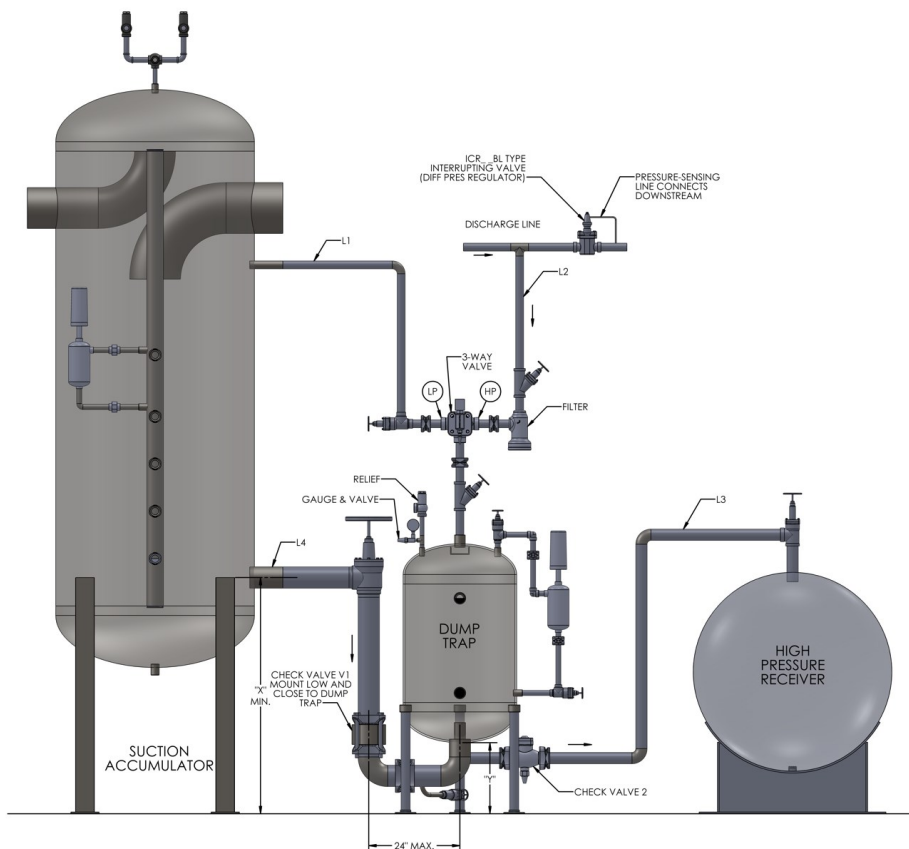

| CATALOG NUMBER* | ACCUM. CAP (TONS) | SYSTEM CAPACITY (GPM) | DUMP TRAP DIA x LNG (IN.) | "X" (MIN REQ'D, IN.) |      | "Y" (REF.) (IN.) | IPS LINE SIZES |        |             |          | SHIPPING WEIGHT (LBS.) |
|-----------------|-------------------|-----------------------|---------------------------|----------------------|------|------------------|----------------|--------|-------------|----------|------------------------|
|                 |                   |                       |                           | VERT.                | HOR. |                  | L1 VENT        | L2 GAS | L3 TRANSFER | L4 DRAIN |                        |
| DK187V/H**      | 120               | 3                     | 12 x 26                   | 30                   | 25   | 10               | 3/4            | 3/4    | 3/4         | 1 1/4    | 270                    |
| DK287V/H        | 200               | 5.1                   | 12 x 26                   | 30                   | 25   | 10               | 3/4            | 3/4    | 3/4         | 1 1/2    | 285                    |
| DK387V/H        | 360               | 9.1                   | 16 x 38                   | 40                   | 30   | 11               | 3/4            | 3/4    | 1 1/4       | 2        | 430                    |
| DK487V/H        | 560               | 14.2                  | 20 x 40                   | 46                   | 35   | 13               | 1 1/4          | 1 1/4  | 1 1/4       | 3        | 670                    |
| DK587V/H        | 1160              | 29.2                  | 24 x 42                   | 47                   | 42   | 16               | 1 1/4          | 1 1/4  | 2           | 4        | 810                    |

**Ordering Instructions:**

Order "DK" System based on accumulator tonnage.

\* When ordering, specify suffix "V" (for vertical dump trap) or suffix "H" (for horizontal dump trap).

\*\* Do not use 187 size systems when accumulator suction temperature is below 0°F. Upsize to 287 system.

If system is to be used for Halocarbon refrigerant, use 1/4 of the tonnage ratings shown for R-717.

Add an "F" in front of the Catalog Number. Seal cap valves and accessories will be furnished.

| INTERRUPTING VALVES FOR DK SYSTEMS |                   |                 |                        |
|------------------------------------|-------------------|-----------------|------------------------|
| VALVE CATALOG NUMBER               | PLANT TONS (R717) | PIPE SIZE (IPS) | SHIPPING WEIGHT (LBS.) |
| ICR40BL                            | 80                | 1 1/2 ; 2       | 40                     |
| ICR50BL                            | 140               | 2               | 55                     |
| ICR65BL                            | 320               | 3               | 175                    |
| ICR80BL                            | 640               | 4               | 265                    |
| ICR100BL                           | 1160              | 5               | 380                    |
| ICR125BL                           | 1800              | 6               | 400                    |

\*Interrupting valve sold separately

**Ordering Instructions:**

Order interrupting valve based on tonnage of the discharge line to be used for its installation.

Never use an interrupting valve that is more than one pipe size smaller than the usable discharge line.

Type G - Compressor Protection System

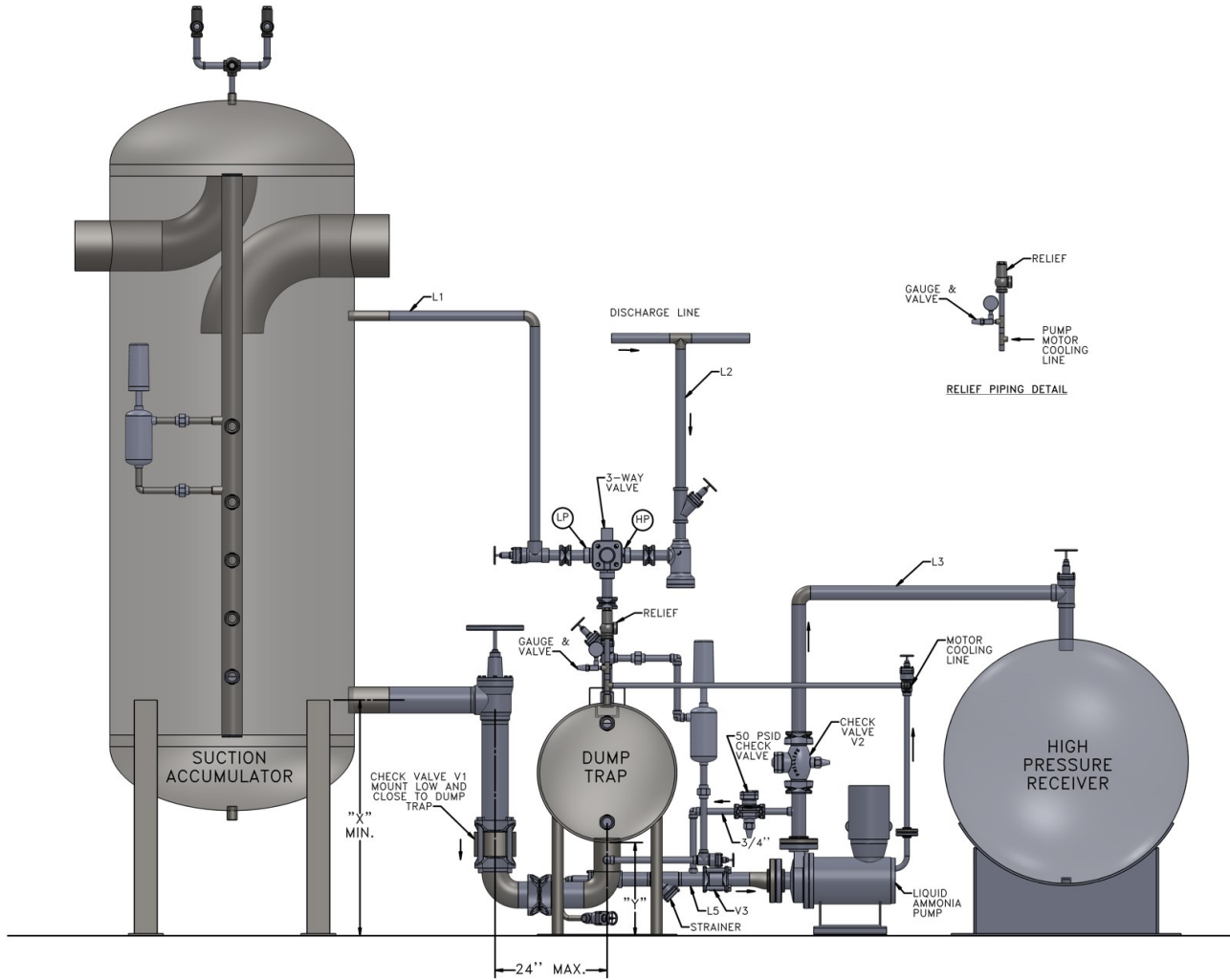

| CATALOG NUMBER* | ACCUM. CAP (TONS) | SYSTEM CAPACITY (GPM) | DUMP TRAP DIA x LNG (IN.) | NIKKISO               |      |                  |                 | TEIKOKU               |      |                  |                 | CORKEN                |      |                  |                 | IPS LINE SIZES |               |             |          |                 | SHIPPING WEIGHT (LBS.) |
|-----------------|-------------------|-----------------------|---------------------------|-----------------------|------|------------------|-----------------|-----------------------|------|------------------|-----------------|-----------------------|------|------------------|-----------------|----------------|---------------|-------------|----------|-----------------|------------------------|
|                 |                   |                       |                           | "X" (MIN REQ'D) (IN.) |      | "Y" (REF.) (IN.) | PUMP MOTOR (HP) | "X" (MIN REQ'D) (IN.) |      | "Y" (REF.) (IN.) | PUMP MOTOR (HP) | "X" (MIN REQ'D) (IN.) |      | "Y" (REF.) (IN.) | PUMP MOTOR (HP) | L1 VENT        | L2 GAS SUPPLY | L3 TRANSFER | L4 DRAIN | L5 PUMP SUCTION |                        |
|                 |                   |                       |                           | VERT.                 | HOR. |                  |                 | VERT.                 | HOR. |                  |                 | VERT.                 | HOR. |                  |                 |                |               |             |          |                 |                        |
| G187V/H**       | 120               | 3                     | 12 x 26                   | 33                    | 28   | 13*              | 2.17            | 32                    | 27   | 12*              | 1.7             | 30                    | 25   | 10               | ¾               | ¾              | ¾             | 1           | 1¼       | 1¼              | 515                    |
| G287V/H         | 170               | 4.3                   | 12 x 26                   | 33                    | 28   | 13*              | 2.17            | 32                    | 27   | 12*              | 1.7             | 30                    | 25   | 10               | ¾               | ¾              | ¾             | 1           | 1¼       | 1¼              | 535                    |
| G387V/H         | 360               | 9                     | 16 x 38                   | 42                    | 32   | 13*              | 2.17            | 42                    | 32   | 13*              | 1.7             | 40                    | 30   | 11               | 2               | ¾              | ¾             | 1¼          | 2        | 1½              | 750                    |
| G487V/H         | 560               | 14                    | 20 x 40                   | 46                    | 35   | 13               | 2.17            | 46                    | 35   | 13               | 1.7             | 46                    | 35   | 13               | 2               | 1¼             | 1¼            | 1¼          | 3        | 1½              | 1060                   |
| G587V/H         | 1040              | 26                    | 24 x 42                   | 47                    | 42   | 16               | 3.21            | 47                    | 42   | 16               | 1.7             | 47                    | 42   | 16               | 3               | 1¼             | 1¼            | 2           | 4        | 2               | 1695                   |
| G687H           | 1200              | 30                    | 24 x 72                   | SP.                   | 42   | 16               | 3.21            | SP.                   | 42   | 16               | 1.7             | SP.                   | 42   | 16               | 3               | 1¼             | 1¼            | 3           | 4        | 3               | 2000                   |
| G787H           | 2000              | 50                    | 24 x 84                   | SP.                   | 42   | 16               | 3.21            | SP.                   | 42   | 16               | 5.2             | SP.                   | 42   | 16               | 5               | 2              | 1¼            | 3           | 4 (2)    | 3               | 2600                   |

**Ordering Instructions:**

- \* When ordering, specify suffix "V" (for vertical dump trap) or suffix "H" (for horizontal dump trap).
- \*\* Do not use 187 size systems when accumulator suction temperature is below 0°F. Upsize to 287 system.

If system is to be used for Halocarbon refrigerant, use 1/4 of the tonnage ratings shown for R-717. Add an "F" in front of the Catalog Number. Seal cap valves and accessories will be furnished.

The standard wired control panel is 120V control; motors are 460/3/60 voltage

The standard Teikoku or Nikkiso pump furnished with the systems above is a sealless hermetic pump, and operates to a minimum of -50°F. Corken pumps are mechanically sealed and operate to a minimum temperature of -20°F. Optional pumps, including magnetic drive pumps, may require changes to piping schematic.



## Packaged Mechanical Pump Recirculators

### Pump Recirculator Packages

Each Phillips mechanical Pump recirculating system is custom-designed and trimmed out to customer's specification

#### Standard Features:

- 250# ASME Recirculator Vessel, National Board Listed, custom designed to meet liquid-vapor separation and surge requirements
- 300# ASME Oil Pot, fully trimmed and piped
- Valved and flanged level column with Phillips Level Eye® sight glasses, mounted high level float switch and drain valve
- Customer's choice of pump manufacturer/type, selected for "standard" 30 psid and 3:1 recirculation
  - \* Nikkiso Sealless
  - \* Teikoku Sealless
  - \* Cornell HT Hermetic
- Dual relief assembly for main recirculator vessel, single relief valve for oil pot
- Piping complete with pump suction service valves, discharge stop and check valves, bypass hand expansion valves, pump relief and motor cooling recirculation valves.
- Welded structural steel base
- Check valves are H.A. Phillips
- 1 coat primer and 4-6 mils of engineered epoxy top coat

#### Common Optional Equipment:

##### Level Control:

- Multiple float switches for low level, operating level and upper level
- Level probe
- Electric controller to interpret probe signal

##### Liquid Makeup:

- Conventional solenoid valve with strainer and expansion valve with expansion valve bypass loop
- Motorized valve with solenoid for power failure protection, with expansion bypass loop
- Danfoss ICF packaged valve station

##### NEMA4 Control Panel:

- Modbus RS485 Serial Communication
- Door mounted controller and LED liquid level indicator
- Liquid level and cavitation control capabilities
- Includes main disconnect and pump starters, factory mounted and wired
- Optional alarm horn and silence (ships loose)

#### Other Available Options:

- Post Weld Heat Treatment
- Vessel Pressure ratings other than 250 psig
- Oil Pot heater: 1.5kW or 2kW with integral thermostat
- Pump requirements other than 30 psid or 3:1 recirculation
- Valve packages using manufacturers other than Danfoss or Phillips
- Low temperature piping components when necessary
  - \*Will use ASME B31.5 low temp pipe exemption when allowed
- Factory wiring
- Sandblasting (SSPC-SP 6)
- Special paint



### PUMP CAPACITY REQUIREMENTS NH3 FLOW GPM PER TON

| OVERFEED RATE | EVAPORATOR TEMPERATURE (°F) |      |      |      |      |      |      |      |      |
|---------------|-----------------------------|------|------|------|------|------|------|------|------|
|               | 30°                         | 20°  | 10°  | 0°   | -10° | -20° | -30° | -40° | -50° |
| 3 : 1         | .206                        | .201 | .196 | .191 | .186 | .182 | .178 | .174 | .171 |
| 4 : 1         | .275                        | .268 | .261 | .254 | .249 | .243 | .238 | .232 | .228 |
| 6 : 1         | .412                        | .401 | .391 | .382 | .373 | .364 | .356 | .349 | .342 |

**Packaged Mechanical Pump Recirculators**

|        | EVAPORATOR TEMPERATURE, °F |      |      |      |      |             |      |      |      |      |
|--------|----------------------------|------|------|------|------|-------------|------|------|------|------|
|        | SINGLE STAGE*              |      |      |      |      | TWO STAGE** |      |      |      |      |
|        | 30                         | 20   | 10   | 0    | -10  | -20         | -20  | -30  | -40  | -50  |
| PVR24  | 172                        | 155  | 138  | 123  | 109  | 96          | 114  | 100  | 87   | 75   |
| PVR30  | 272                        | 245  | 219  | 195  | 173  | 152         | 181  | 158  | 138  | 119  |
| PVR36  | 396                        | 356  | 319  | 284  | 251  | 221         | 263  | 230  | 200  | 173  |
| PVR42  | 543                        | 488  | 437  | 389  | 344  | 303         | 360  | 316  | 274  | 237  |
| PVR48  | 712                        | 640  | 573  | 510  | 452  | 398         | 473  | 414  | 360  | 311  |
| PVR54  | 896                        | 806  | 721  | 642  | 569  | 501         | 595  | 521  | 453  | 391  |
| PVR60  | 1110                       | 999  | 894  | 796  | 705  | 621         | 738  | 646  | 562  | 485  |
| PVR72  | 1597                       | 1436 | 1286 | 1145 | 1014 | 893         | 1061 | 929  | 808  | 697  |
| PVR84  | 2172                       | 1953 | 1748 | 1557 | 1379 | 1214        | 1443 | 1264 | 1099 | 949  |
| PVR96  | 2850                       | 2563 | 2294 | 2043 | 1810 | 1593        | 1894 | 1659 | 1442 | 1245 |
| PVR108 | 3602                       | 3240 | 2900 | 2583 | 2288 | 2014        | 2394 | 2097 | 1823 | 1574 |
| PVR120 | 4443                       | 3996 | 3571 | 3186 | 2822 | 2484        | 2953 | 2586 | 2249 | 1941 |
| PVR144 | 6389                       | 5747 | 5144 | 4582 | 4058 | 3572        | 4247 | 3719 | 3234 | 2791 |

\* Single stage capacities based on 96°F liquid supply

\*\* Two stage capacities based on +20°F liquid supply

| Surge Volume | Estimated Ship Wt |
|--------------|-------------------|
| 14.0         | 2700              |
| 20.7         | 3000              |
| 30.0         | 3400              |
| 55.0         | 4000              |
| 69.2         | 4400              |
| 83.2         | 5600              |
| 98.4         | 7100              |
| 121          | 9200              |
| 147          | 13700             |
| 220          | 15800             |
| 278          | 19800             |
| 292          | 24800             |
| 422          | 36600             |

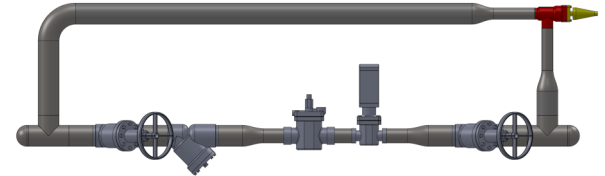
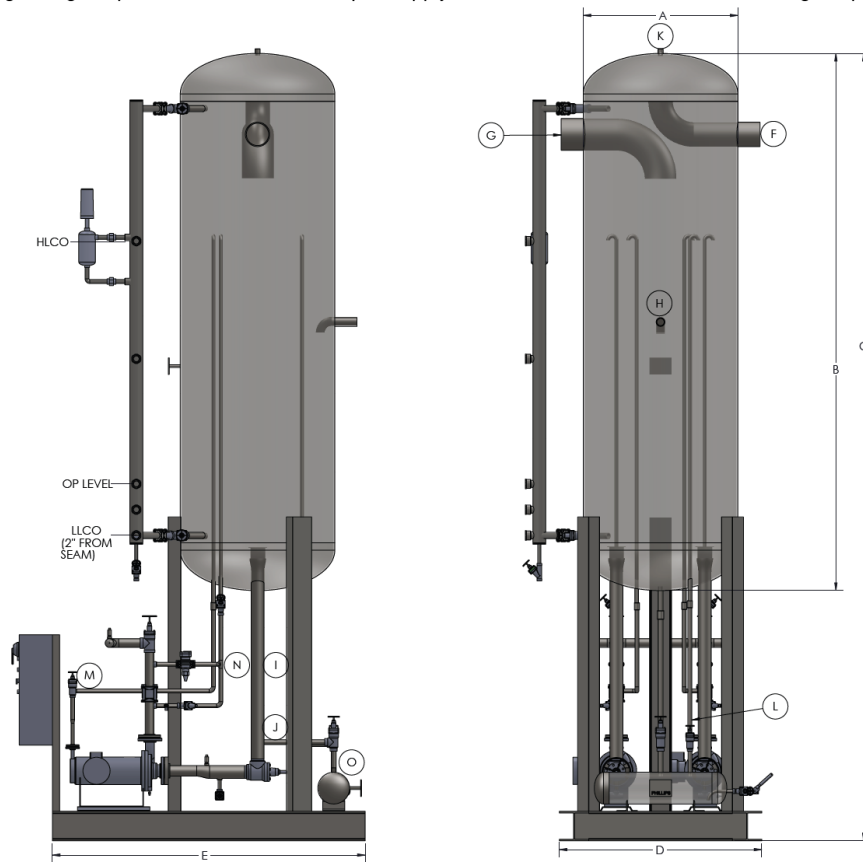

**Valve Trains**

\* Solenoid, motorized valve, or pulse-width modulated control

\* Danfoss, Hansen, or Parker valves available

| Model Number | A   | B   | C      | D          | E           | F           | G           | H         | I            | J              | K      | L            | M                  | N      | O       | LLCO* | OP Level* | HLCO* |
|--------------|-----|-----|--------|------------|-------------|-------------|-------------|-----------|--------------|----------------|--------|--------------|--------------------|--------|---------|-------|-----------|-------|
|              | OD  | OAH | Pkg Ht | Base Width | Base Length | Wet Suction | Dry Suction | Liq. Feed | Pump Suction | Oil Pot Drain† | Relief | Oil Pot Vent | Pump Vent/ Cooling | Bypass | Oil Pot |       |           |       |
| PVR24        | 24  | 113 | 179    | 42         | 75          | 6           | 5           | 1 1/4     | 4            | 1              | 3/4    | 3/4          | 3/4                | 3/4    | 8 x 36  | 2     | 16        | 73    |
| PVR30        | 30  | 116 | 182    | 55         | 75          | 8           | 6           | 1 1/2     | 4            | 1              | 3/4    | 3/4          | 3/4                | 3/4    | 8 x 36  | 2     | 16        | 69    |
| PVR36        | 36  | 119 | 185    | 65         | 84          | 8           | 6           | 2         | 4            | 1              | 3/4    | 3/4          | 3/4                | 3/4    | 8 x 36  | 2     | 16        | 69    |
| PVR42        | 42  | 146 | 214    | 55         | 85          | 10          | 8           | 2 1/2     | 4            | 1              | 3/4    | 3/4          | 3/4                | 3/4    | 8 x 36  | 2     | 16        | 87    |
| PVR48        | 48  | 149 | 215    | 62         | 90          | 10          | 10          | 2 1/2     | 4            | 1              | 3/4    | 3/4          | 3/4                | 3/4    | 8 x 36  | 2     | 16        | 84    |
| PVR54        | 54  | 152 | 221    | 68         | 96          | 12          | 10          | 3         | 5            | 1              | 3/4    | 3/4          | 3/4                | 3/4    | 8 x 36  | 2     | 16        | 81    |
| PVR60        | 60  | 155 | 223    | 72         | 96          | 12          | 12          | 3         | 5            | 1 1/4          | 3/4    | 3/4          | 3/4                | 1      | 10 x 36 | 2     | 16        | 78    |
| PVR72        | 72  | 161 | 227    | 78         | 112         | 16          | 14          | 4         | 6            | 1 1/4          | 3/4    | 3/4          | 3/4                | 1      | 10 x 36 | 2     | 16        | 69    |
| PVR84        | 84  | 167 | 233    | 98         | 124         | 18          | 16          | 5         | 8            | 1 1/2          | 3/4    | 1            | 3/4                | 1 1/4  | 12 x 36 | 2     | 16        | 63    |
| PVR96        | 96  | 173 | 239    | 102        | 128         | 20          | 18          | 5         | 8            | 1 1/2          | 3/4    | 1            | 3/4                | 1 1/4  | 12 x 36 | 2     | 16        | 70    |
| PVR108       | 108 | 179 | 245    | 114        | 132         | 20          | 20          | 6         | 10           | 1 1/2          | 1      | 1            | 3/4                | 1 1/4  | 12 x 36 | 2     | 16        | 70    |
| PVR120       | 120 | 185 | 251    | 126        | 132         | 24          | 24          | 6         | 10           | 1 1/2          | 1      | 1            | 3/4                | 1 1/2  | 12 x 36 | 2     | 16        | 62    |
| PVR144       | 144 | 197 | 263    | 150        | 156         | 24          | 24          | 8         | 12           | 1 1/2          | 1 1/4  | 1            | 3/4                | 1 1/2  | 12 x 36 | 2     | 16        | 62    |

\* Dimensions are taken from lower head/shell seam.

†For temperatures below -20° oil drain size is 1-1/2"

All vessels are custom-built to customer specifications. Vessel dimensions and nozzle sizes in tables are suggestions for nominal conditions.

Packaged Mechanical Pump Recirculators

|        | EVAPORATOR TEMPERATURE, °F |      |      |      |      |             |      |      |      |      |
|--------|----------------------------|------|------|------|------|-------------|------|------|------|------|
|        | SINGLE STAGE*              |      |      |      |      | TWO STAGE** |      |      |      |      |
|        | 30                         | 20   | 10   | 0    | -10  | -20         | -20  | -30  | -40  | -50  |
| PHR24  | 131                        | 118  | 106  | 94   | 83   | 73          | 87   | 76   | 66   | 57   |
| PHR30  | 202                        | 182  | 163  | 145  | 128  | 113         | 134  | 117  | 102  | 88   |
| PHR36  | 313                        | 282  | 252  | 225  | 199  | 175         | 208  | 182  | 153  | 127  |
| PHR42  | 419                        | 377  | 337  | 301  | 266  | 234         | 279  | 244  | 212  | 183  |
| PHR48  | 572                        | 514  | 460  | 410  | 363  | 319         | 380  | 333  | 289  | 250  |
| PHR54  | 737                        | 663  | 594  | 529  | 465  | 405         | 477  | 418  | 363  | 313  |
| PHR60  | 911                        | 819  | 733  | 653  | 578  | 509         | 605  | 530  | 461  | 398  |
| PHR72  | 1328                       | 1194 | 1069 | 952  | 843  | 742         | 849  | 744  | 647  | 558  |
| PHR84  | 1795                       | 1615 | 1445 | 1287 | 1140 | 1004        | 1159 | 1015 | 883  | 762  |
| PHR96  | 2354                       | 2117 | 1895 | 1688 | 1495 | 1316        | 1518 | 1320 | 1148 | 998  |
| PHR108 | 3031                       | 2727 | 2345 | 2089 | 1850 | 1628        | 1936 | 1695 | 1474 | 1272 |
| PHR120 | 3670                       | 3301 | 2955 | 2631 | 2330 | 2052        | 2439 | 2136 | 1858 | 1603 |
| PHR144 | 5421                       | 4876 | 4365 | 3887 | 3443 | 3031        | 3604 | 3156 | 2744 | 2368 |

| Surge Volume | Estimated Ship Wt |
|--------------|-------------------|
| 8.7          | 3100              |
| 14.8         | 3400              |
| 22.3         | 3900              |
| 28.7         | 4200              |
| 39.4         | 4600              |
| 50.6         | 5800              |
| 63.9         | 7300              |
| 90.2         | 9400              |
| 127          | 13700             |
| 168          | 15800             |
| 222          | 19600             |
| 276          | 24600             |
| 402          | 36200             |

\* Single stage capacities based on 96°F liquid supply

\*\* Two stage capacities based on +20°F liquid supply

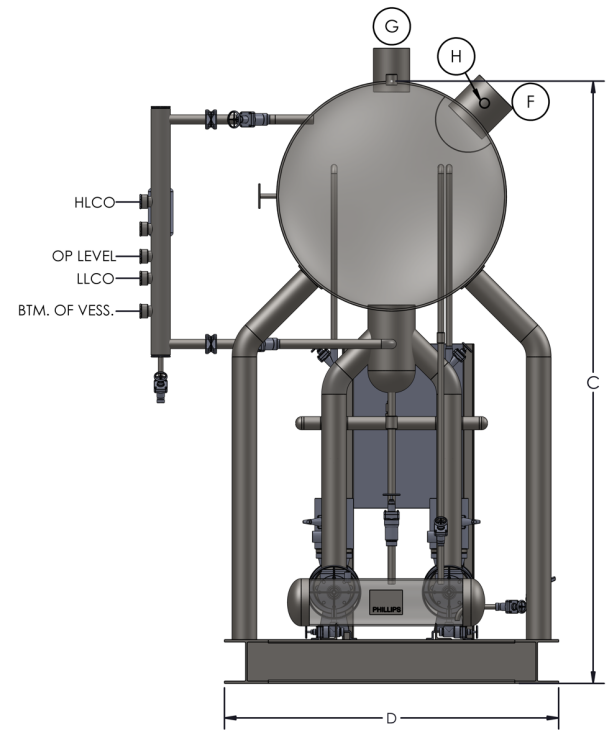
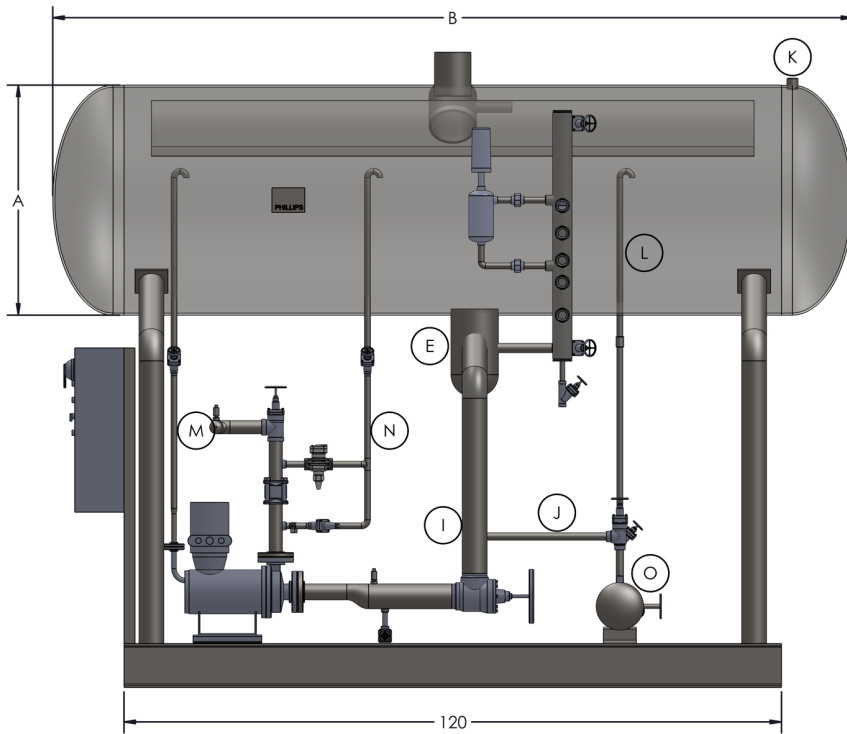

| Model Number | A   | B   | C      | D          | E    | F           | G           | H         | I            | J              | K      | L            | M                  | N      | O       | LLCO* | OP LEVEL* | HLCO* |
|--------------|-----|-----|--------|------------|------|-------------|-------------|-----------|--------------|----------------|--------|--------------|--------------------|--------|---------|-------|-----------|-------|
|              | OD  | OAL | Pkg Ht | Base Width | Sump | Wet Suction | Dry Suction | Liq. Feed | Pump Suction | Oil Pot Draint | Relief | Oil Pot Vent | Pump Vent/ Cooling | Bypass | Oil Pot |       |           |       |
| PHR24        | 24  | 137 | 90     | 60         | 8    | 6           | 5           | 1-1/4     | 4            | 1              | 3/4    | 3/4          | 3/4                | 3/4    | 8 x 36  | 4     | 6         | 12    |
| PHR30        | 30  | 140 | 96     | 60         | 10   | 8           | 6           | 1-1/2     | 4            | 1              | 3/4    | 3/4          | 3/4                | 3/4    | 8 x 36  | 4     | 7         | 15    |
| PHR36        | 36  | 143 | 102    | 60         | 12   | 8           | 6           | 1-1/2     | 4            | 1              | 3/4    | 3/4          | 3/4                | 3/4    | 8 x 36  | 4     | 8         | 18    |
| PHR42        | 42  | 146 | 110    | 62         | 14   | 10          | 8           | 2         | 4            | 1              | 3/4    | 3/4          | 3/4                | 3/4    | 8 x 36  | 6     | 10        | 21    |
| PHR48        | 48  | 149 | 116    | 65         | 14   | 10          | 8           | 2-1/2     | 4            | 1              | 3/4    | 3/4          | 3/4                | 3/4    | 8 x 36  | 6     | 11        | 24    |
| PHR54        | 54  | 152 | 120    | 72         | 16   | 10          | 10          | 2-1/2     | 4            | 1              | 3/4    | 3/4          | 3/4                | 1      | 8 x 36  | 6     | 12        | 27    |
| PHR60        | 60  | 155 | 126    | 72         | 4    | 12          | 10          | 3         | 5            | 1-1/4          | 3/4    | 3/4          | 3/4                | 1      | 10 x 36 | 6     | 13        | 30    |
| PHR72        | 72  | 161 | 138    | 84         | 4    | 14          | 12          | 4         | 6            | 1-1/4          | 3/4    | 3/4          | 3/4                | 1      | 10 x 36 | 8     | 16        | 36    |
| PHR84        | 84  | 167 | 156    | 96         | 4    | 16          | 16          | 4         | 8            | 1-1/2          | 3/4    | 1            | 3/4                | 1      | 12 x 36 | 8     | 18        | 42    |
| PHR96        | 96  | 173 | 168    | 96         | 4    | 18          | 16          | 5         | 8            | 1-1/2          | 3/4    | 1            | 3/4                | 1-1/4  | 12 x 36 | 8     | 20        | 48    |
| PHR108       | 108 | 179 | 180    | 96         | 4    | 20          | 18          | 5         | 8            | 1-1/2          | 1      | 1            | 3/4                | 1-1/4  | 12 x 36 | 8     | 21        | 54    |
| PHR120       | 120 | 185 | 192    | 108        | 4    | 24          | 20          | 6         | 10           | 1-1/2          | 1      | 1            | 3/4                | 1-1/2  | 12 x 36 | 8     | 23        | 60    |
| PHR144       | 144 | 197 | 216    | 120        | 4    | 24          | 24          | 8         | 12           | 1-1/2          | 1-1/4  | 1            | 3/4                | 1-1/2  | 12 x 36 | 8     | 27        | 72    |

\* Dimensions are taken from bottom of vessel  
 †For temperatures below -20° oil drain size is 1-1/2"

All vessels are custom-built to customer specifications. Vessel dimensions and nozzle sizes in tables are suggestions for nominal conditions.

## Plate and Frame Packaged System

Phillips offers packaging of plate and frame-type heat exchangers. We can supply the complete package, or you can have the manufacturer of the heat exchanger ship it to our factory for packaging. Have our expert fitters do the packaging in a controlled factory environment.

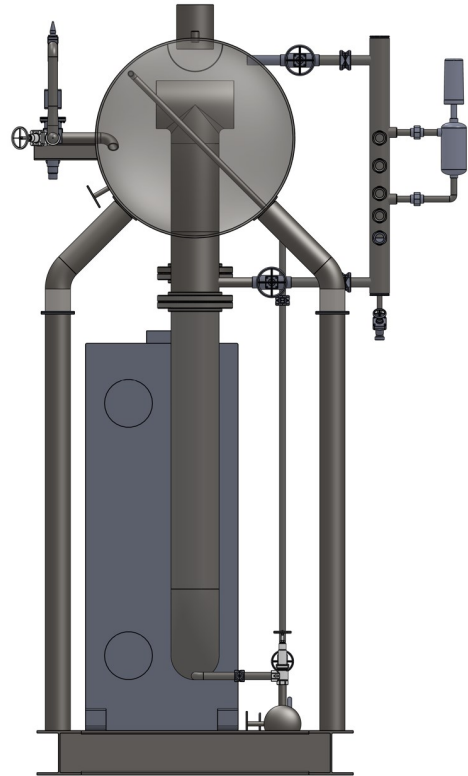
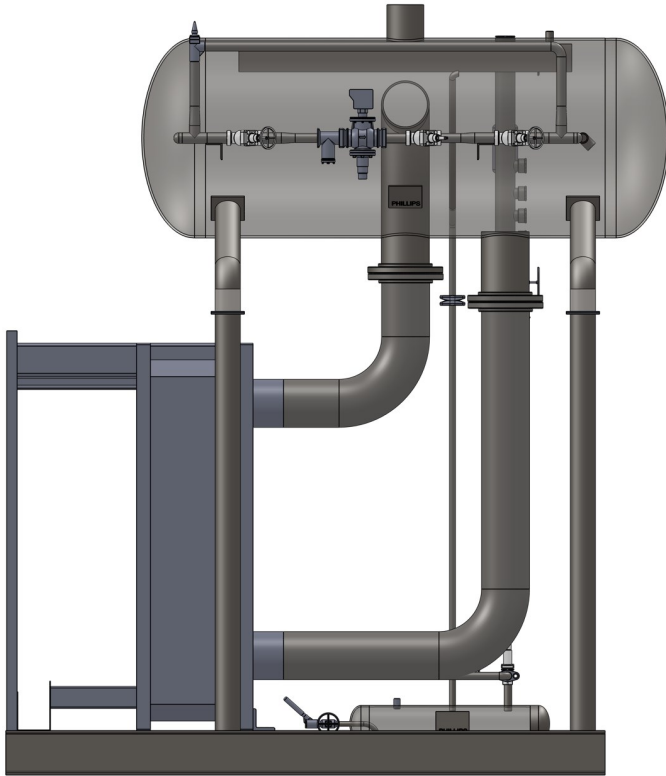

### STANDARD OFFERINGS:

- Split-flow horizontal surge drum (see ratings on page 2, vessel design on page 17)
- Dual relief assembly for package (ships loose)
- Oil Pot with full trim (relief valve ships loose)
- Valved and flanged level column with Level Eye® sight glasses and factory installed HLCO float switch and drain valve
- Danfoss level sensor and controller
- Danfoss shutoff valves
- Structural steel base
- 1 coat primer and 4-6 mils of engineered epoxy top coat

### OPTIONS:

- Liquid makeup valve train
  - \* Solenoid control with hand expansion bypass loop
  - \* Motorized valve with solenoid power-loss protection, with hand expansion bypass loop
  - \* Danfoss ICF valve station
- Electric oil pot heater with integral thermostat, in various voltages and kW
- Stop valves to isolate PHE
- Dual relief assembly for PHE
- Post weld heat treatment of surge drum
- Sandblasting and special coatings
- Alternate level sensors and controllers (Hansen, R/S, others)
- Alternate valve suppliers (Hansen, R/S, others)
- UL/NEMA4 Control Panel

When requesting quote, please indicate PHE selection details (tonnage, suction temperature, and dimensions), as well as desired options.

Concept Sketch Sheet - Level Eye® Column

**Column Quote Request**

Column OD:  2"  2-1/2"  3"  
 Shell Length: \_\_\_\_\_"  
 Level Eyes

Qty: \_\_\_\_\_  
 Type:  1100C-R  1100C-RN  1100C-RNX  \_\_\_\_\_

**Standard Connections:**

- 3/4" Mounted Drain Valve (bottom)
- 3/4" Probe/Vent (top)
- (2) 3/4" Float Switch Mounting Cplgs (side) \_\_\_\_\_ Sets
- (2) 1-1/4" Vessel Mounting Pipes (side) \_\_\_\_\_ Other Size

**Options:**

- Mounted Float Switch \_\_\_\_\_ LLSS \_\_\_\_\_ Other
- Other Size Drain Valve \_\_\_\_\_ Size
- Stainless Steel (comes with weld caps)

Other details sketched as needed:

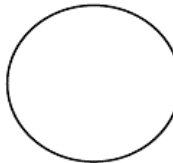

Ref \_\_\_\_\_

Concept Sketch Sheet - Horizontal

**VESSEL CONCEPT VERIFICATION SKETCH**

Vessel OD: \_\_\_\_\_ in.    Vessel O.A.L.: \_\_\_\_\_ in.    Refrigerant: \_\_\_\_\_

**Vessel Type (check one):**

- Accumulator     Receiver     Surge Drum  
 Thermosyphon     Other: \_\_\_\_\_

**Vessel Support (check one):**

- Full Saddle: Number= \_\_\_\_\_     Saddle Piece: Number= \_\_\_\_\_  
 Clips: Number= \_\_\_\_\_     Other \_\_\_\_\_     None

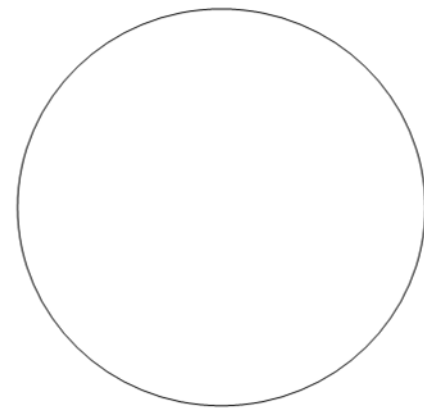
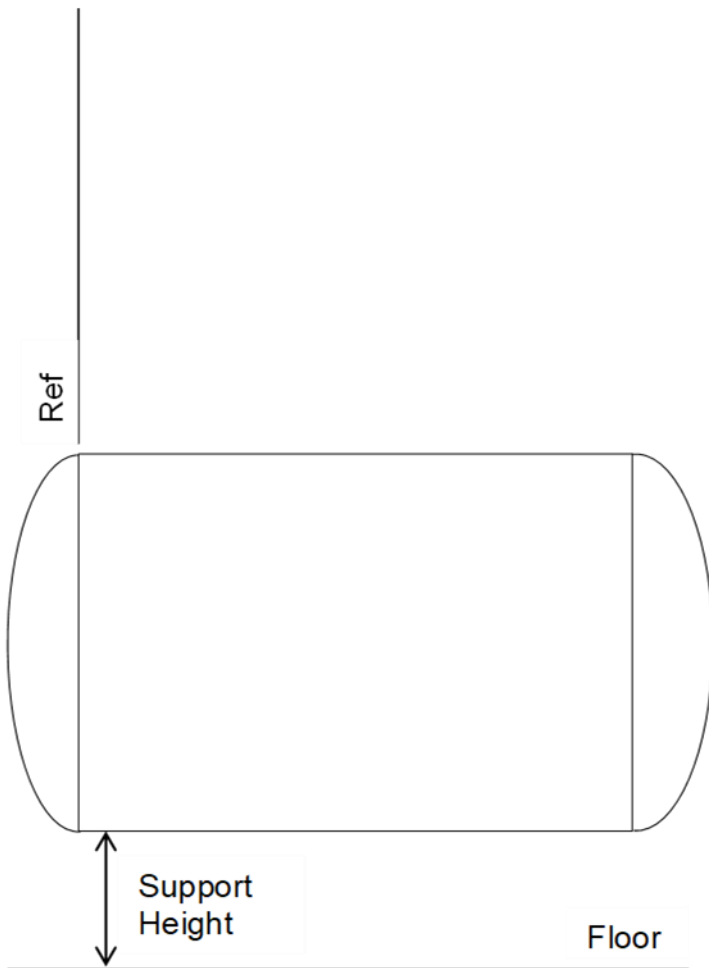

| Nozzle | Size | Purpose |
|--------|------|---------|
| A      |      |         |
| B      |      |         |
| C      |      |         |
| D      |      |         |
| E      |      |         |
| F      |      |         |
| G      |      |         |
| H      |      |         |
| I      |      |         |

Note:  
Sketch any  
baffles or  
internals on  
Drawing.

OPERATING TEMP: \_\_\_\_\_ °F

MAWP: \_\_\_\_\_ °F

Concept Sketch Sheet - Vertical

**VESSEL CONCEPT VERIFICATION SKETCH**

Vessel OD: \_\_\_\_\_ in.    Vessel O.A.H.: \_\_\_\_\_ in.    Refrigerant: \_\_\_\_\_

**Vessel Type (check one):**

- Accumulator   
  Receiver   
  Surge Drum   
  CPR   
  Intercooler  
 Thermosyphon   
 Other: \_\_\_\_\_

**Vessel Support (check one):**

- Pipe Stand (Pedestal): Diameter= \_\_\_\_\_ in.   
 Clips: Number= \_\_\_\_\_  
 Legs: Number/Length= \_\_\_\_/\_\_\_\_ in. (Angle or Channel)   
 None

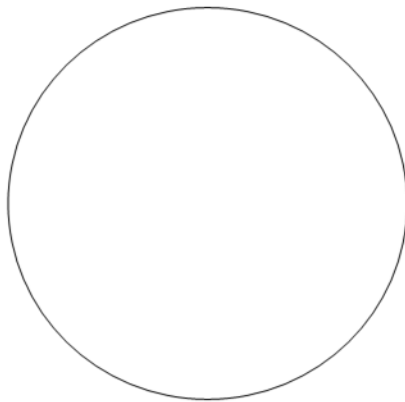

| Nozzle | Size | Purpose |
|--------|------|---------|
| A      |      |         |
| B      |      |         |
| C      |      |         |
| D      |      |         |
| E      |      |         |
| F      |      |         |
| G      |      |         |
| H      |      |         |
| I      |      |         |

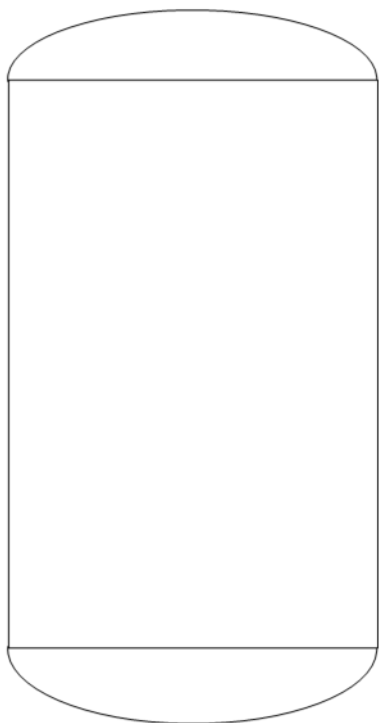

OPERATING TEMP: \_\_\_\_\_ °F

MAWP: \_\_\_\_\_ °F



Note:  
Sketch any  
baffles or  
internals on  
Drawing.

Be Sure to Check Out Our Other Product Catalog!

**Phillips**  
REFRIGERATION  
VALVES • VESSELS • SYSTEMS • CONTROLS

OPTIONAL WATER BUBBLER

VENT

RELIEF

WET SUCTION

LIQUID FEED

LEVEL SENSOR

OUTER DRAIN

INNER DRAIN

FOUL GAS (FROM PURGE POINTS)

AUTOMATED SMART CONTROLS  
3 PT, 10 PT, OR 30 PT OPTIONS

770 Enterprise Avenue  
DeKalb, IL 60115

info@haphillips.com

630.377.0050

H. A. Phillips & Co. | Phillips Auto Purgers | PURGERS-21E

**Phillips**  
REFRIGERATION  
VALVES • VESSELS • SYSTEMS • CONTROLS

For Actual Construction Install Globe Valves with Stems in a Horizontal Position

For Actual Construction Install Globe Valves with Stems in a Horizontal Position

770 Enterprise Avenue  
DeKalb, IL 60115

info@haphillips.com

630.377.0050

H. A. Phillips & Co. | Valves & Accessories Catalog | VB-22E-01



ASME "U"



National Board



ASME "R"



CRN  
Many Products Registered



Bureau Veritas ISO 9001: 2015



IIAR Member  
International Institute of Ammonia Refrigeration



RETA Member