

For Ammonia (R717) and Halocarbon Refrigerants
Available Sizes: 1/2" to 10"

FEATURES

- Forged A105 Steel
- 300 PSI Rating, -50°F to +400°F^{⌘,⌘}
- Tongue & Groove Flange Facings
- Available with Threaded, Socket Weld, Weld Neck (AKA Butt Weld), and ODC/ ODS Connections
- CRN 0B11183.5C

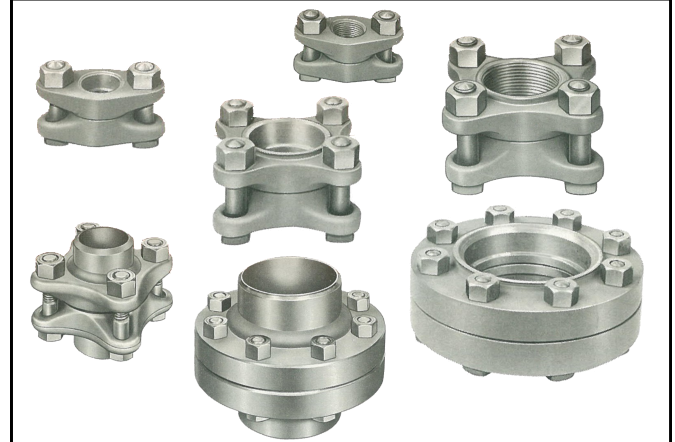

FLANGE, UNION, AND SPARE PART NUMBERS

Style of Flange	Nom. Pipe Size (in.)	Flange Part Numbers (M=Male, F=Female)			Union** Part Numbers			Replacement Parts			
		Socket	Threaded	Weld Neck	Socket	Threaded	Weld Neck	Gasket Part #	Nut Part #	Bolt Part #	Kit Part # ***
Oval 2-Bolt	1/2	4-MS, 4-FS	4-MT, 4-FT	---	U-4S	U-4T	---	728	58	72	KF075
	3/4	6-MS, 6-FS	6-MT, 6-FT	---	U-6S	U-6T	---				
	1	8-MSO, 8-FSO	8-MTO, 8-FTO	---	U-8SO	U-8TO	---	626	58	72	KFO100
Square 4-Bolt	1	8-MS, 8-FS	8-MT, 8-FT	---	U-8S	U-8T	---	63	57	721B	KF125
	1-1/4	10-MS, 10-FS	10-MT, 10-FT	10-MW, 10-FW	U-10S	U-10T	U-10W				
	1-1/2	12-MS, 12-FS	12-MT, 12-FT	12-MW, 12-FW	U-12S	U-12T	U-12W	63W	57	721B	KF150
	2	16-MS, 16-FS	16-MT, 16-FT	16-MW, 16-FW	U-16S	U-16T	U-16W	73	58	72	KF200
	2-1/2	20-MS, 20-FS	---	20-MW, 20-FW	U-20S	---	U-20W	74	59	24A	KF250
	3	24-MS, 24-FS	---	24-MW, 24-FW	U-24S	---	U-24W	326Y	59	24A	KF300
Round 8-Bolt	4	32-MS, 32-FS	---	32-MW, 32-FW	U-32S	---	U-32W	326YA	60	24D	KF400
	5	40-MS, 40-FS	---	40-MW, 40-FW	U-40S	---	U-40W	5G	59	24A	KF500
	5 [⌘]	40-MSY, 40-FSY	---	40-MWY	U-40SY	---	---	5GY	59	24A	KF500Y
	6	48-MS, 48-FS	---	48-MW, 48-FW	U-48S	---	U-48W	6G	59	24A	KF600
	6 [⌘]	48-MSY, 48-FSY	---	48-MWY	U-48SY	---	---	6GY	59	24A	KF600Y
12-Bolt	8 [⌘]	64-MS, 64-FS	---	64-MW, 64-FW	U-64S	---	U-64W	8G	60	24E	KF800
	10 [⌘]	80-MS, 80-FS	---	80-MW, 80-FW	U-80S	---	U-80W	10G	60	24E	KF1000

* These flanges machined to York flange dimensions.

** Unions consist of (1) male flange & (1) female flange; plus all nuts, bolts, and gasket required to make (1) complete flange set.

*** Kits includes one gasket and the required number of nuts and bolts for that flange size.

⌘ These 5", 6", and 8" flanges are rated for 300 PSI, -45 °F to +400 °F.

⌘ This 10" flange is rated for 300 PSI, -41 °F to +400 °F.



SOCKET WELD FLANGE DIMENSIONS* AND WEIGHTS

Style of Flange	Nominal Pipe Size (in.)	A Flange Dimension	B Bolt Center	C Flange Thickness	D Tongue & Groove			G Depth of Socket	Bolt Size	Flange Weight (lbs.)	Union Weight (lbs.)
					I.D.	O.D.	Depth**				
Oval 2-Bolt	1/2	4-3/8	3	15/16	1-1/4	1-7/8	1/8	7/16	5/8	1	3
	3/4	4-3/8	3	15/16	1-1/4	1-7/8	1/8	1/2	5/8	1	3
	1	4-1/2	3-1/8	1-1/8	1-3/8	1-7/8	1/8	1/2	5/8	1.15	3.15
Square 4-Bolt	1	3-1/2	2-3/8	1-1/16	1-3/4	2-3/8	1/8	9/16	1/2	2	5
	1-1/4	3-1/2	2-3/8	1-1/16	1-3/4	2-3/8	1/8	9/16	1/2	1.75	4.5
	1-1/2	4	2-3/4	1-1/8	2	2-3/4	1/8	5/8	1/2	2.25	5.5
	2	4-1/2	3-1/16	1-1/8	2-1/2	3-1/4	1/8	5/8	5/8	2.5	7
	2-1/2	5-1/2	3-7/8	1-1/2	3	3-3/4	1/8	1	3/4	5	12.5
	3	6	4-1/8	1-9/16	3-5/8	4-3/8	1/8	1-1/16	3/4	6	15
Round 8-Bolt	4	7	5	1-7/8	4-3/4	5-1/2	1/8	1-3/8	7/8	9	22
	5	10-1/4	8-1/2	1-3/4	6-1/8	7-1/4	1/8	1-1/4	3/4	20	47
	5*	10-1/4	8-1/2	1-3/4	5-3/4	6-1/2	1/8	1-1/4	3/4	20	47
	6	11-1/4	9-1/2	1-13/16	7-1/8	8-1/4	1/8	1-5/16	3/4	24	55
	6*	12-1/4	9-3/4	1-13/16	7	7-3/4	1/8	1-5/16	3/4	24	55
12-Bolt	8	14-1/4	12	2	9-3/8	10-1/2	3/16	1-1/2	7/8	40	90
	10	16-1/2	14-3/8	2-1/4	11-3/8	12-5/8	3/16	1-3/4	7/8	60	135

All dimensions are in Inches (nominal dimensions).

* Machined to York flange dimensions

** Tongue dimension is 1/32" greater than groove dimension.

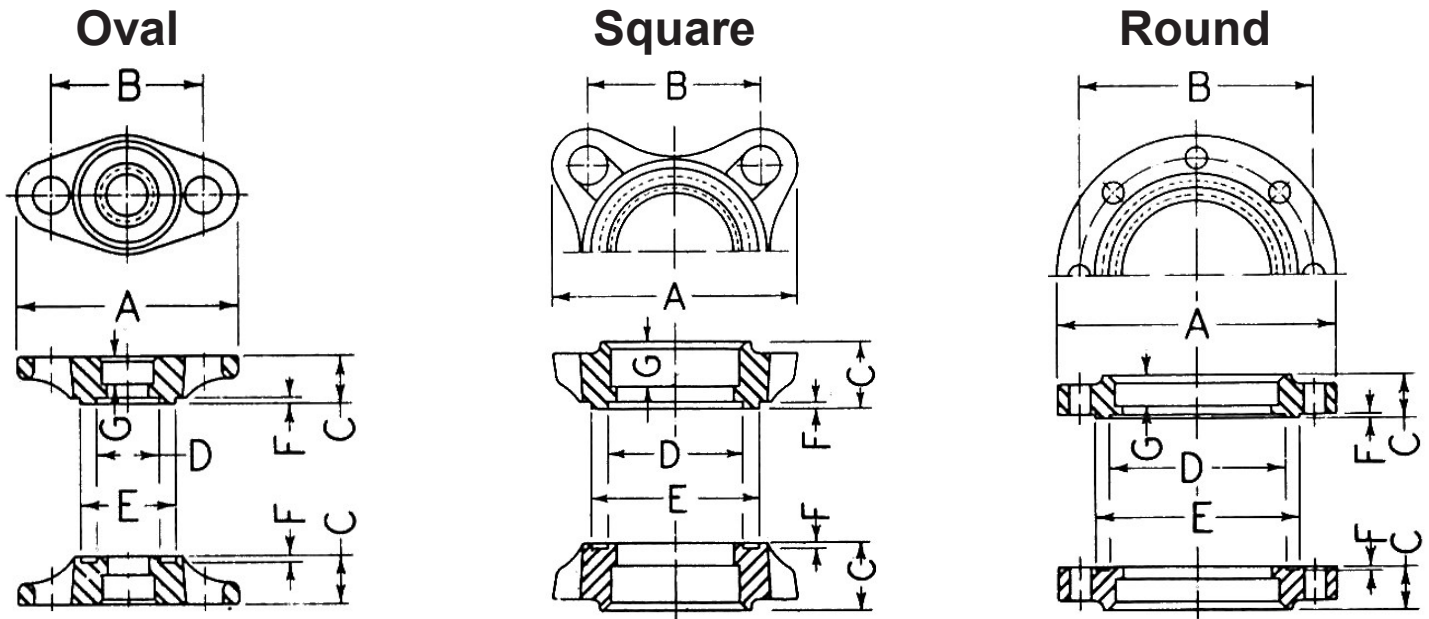

❖ Besides the flanges that are machined to York flange dimensions (denoted with a single star in the above tables), ODS flanges, and 1" Oval 2-Bolt flanges, all other flanges are machined to Wolf-Linde dimensions. In 1998, Phillips acquired the manufacturing rights to the flanges and check valves formerly sold by Wolf-Linde, Inc.

For more information, please click on the Wolf-Linde logo to the right to be directed to an old Wolf-Linde catalog:

Wolf-Linde

Please consult our factory for specialty flange inquiries such as reducing flanges, and flanges with copper connections.



H.A. Phillips & Co.
770 Enterprise Avenue
DeKalb, IL 60115 U.S.A.
Phone: (630) 377-0050

