

Data sheet – Spare parts and accessories

Liquid level sensor
Type AKS 4100/4100U

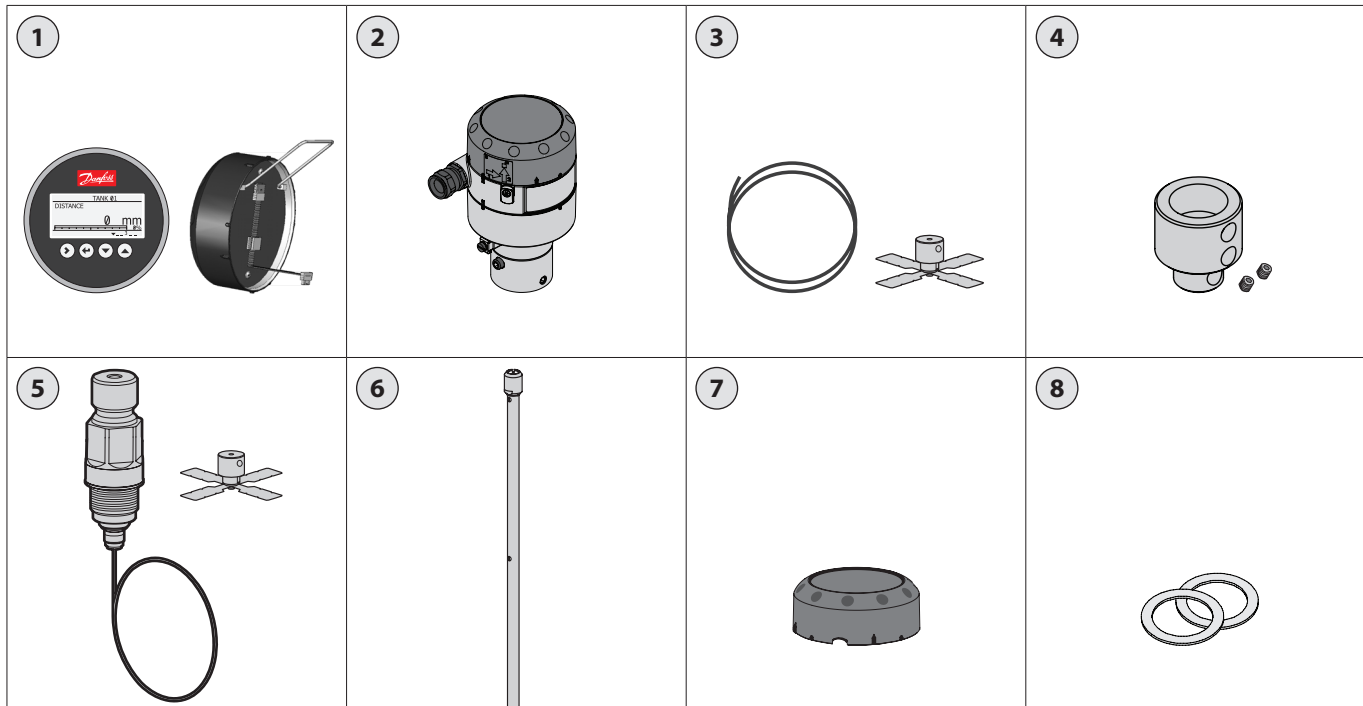

Description	Fig.. #	Qty.	Code no.
Accessories			
AKS 4100/4100U HMI Service/Display unit with rear cover and mounting bracket	1	1	084H4540
AKS 4100/4100U HMI Display	1	1	084H4548
AKS 4100/4100U Signal Converter without HMI, excluding cable gland	2	1	084H4541
Service kit			
Cable and counterweight for AKS 4100/4100U - CABLE version			
Cable - 5 m (197 in.) Ø2 mm (Ø0.08 in.)	3	1	084H4542
Crimp	3	1	
Counterweight	3	1	
Service kit			
End connector incl screws for AKS 4100/4100U - COAXIAL version			
End connector (incl. 3 mm (0.12 in) set screws)	4	1	084H4549
Service kit			
Process connection, counterweight and 5 m (197 in.) Ø2 mm (Ø0.08 in.) cable for AKS 4100 - CABLE and COAXIAL version			
1 in. process connection	5	1	084H4545
Counterweight	5	1	

Description	Fig.. #	Qty.	Code no.
Service kit			
Process connection, counterweight and 5 m (197 in.) Ø2 mm (Ø0.08 in.) cable for AKS 4100U - CABLE and COAXIAL version			
3/4in. NPT process connection	5	1	084H4546
Counterweight	5	1	
Other spare parts			
Coaxial tube. Tube length : 680 mm (26.8 in.)	6	1	084H4543
Blank top cover for signal converter	7	1	084H4544
Aluminium gaskets for 1in. process connection	8	10	084H4547
AKS 4100 1. in. welding connection	-	1	027F1010