

System drawings shown in this bulletin are for illustration purposes only. Refrigeration systems should only be serviced by a qualified technician. Always observe proper safety procedures when servicing a refrigeration system. For more information see the latest revision of Phillips Safety Bulletin SGRV.

GENERAL INFORMATION

Pressure Rating: 300 psig [21 bar, gauge]

MOPD: 250 psi [17 bar]
(120 psi [8 bar] 301H w/ 9/32" cartridge)

Temperature Rating: -20°F to 240°F
[-29°C to 116°C]

The 301H Series of remote-feed low-side float valves are fixed-level modulating controls which open with a drop in liquid level. Valves in this series include the 301A and 301H valves for ammonia systems, and the 301AF and 301HF for halocarbon systems. Parts for all of these valves are interchangeable, except for the float ball. These valves incorporate a replaceable cartridge, which contains the working needle and seat, which can be changed without pumping down the surge drum or evaporator through the use of the manual stem.

VALVE OPERATION

The valve is operated by the movement of a float ball, which rises and falls in response to the changing liquid level inside the surge drum. High pressure liquid enters an inlet cavity containing the cartridge

through either of two 3/4" FPT connections on the sides of the valve body. If the liquid level in the surge drum is low, the float ball falls causing the end of the float rod (343H) to press the cam needle (314) against the pusher assembly (357, 358, 359). See Figure 1. The pusher assembly, in turn, presses a pin extending out the end of the cartridge. This pin pushes the needle off the seat and allows liquid to flow from the inlet cavity through the cartridge and into the liquid outlet cavity. Liquid then flows out through the remote feed connection, into the surge drum or evaporator. When the liquid level inside the surge drum rises, the float ball rises and a spring inside the cartridge pushes the needle against the seat and stops flow.

The manual stem is provided to allow the cartridge to be changed without the need for pumping down the vessel. The procedure for changing the cartridge is described in more detail later in this bulletin. Screwing the manual stem completely inward forces the cam needle to fully seat, isolating the cartridge. The manual stem should not be used as a means for limiting cartridge movement during normal operation or as a bypass. Doing so can result in premature cartridge wear.

Figure 1: Valve Operation

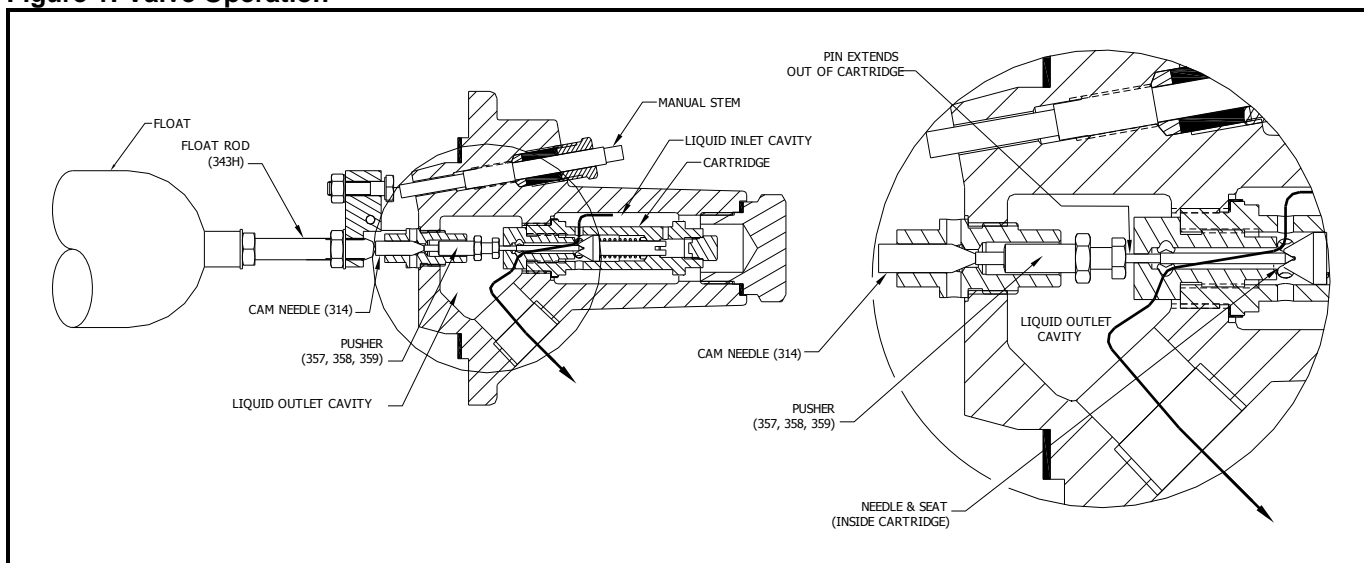

INSTALLATION

When mounting the valve on a vessel, care should be taken that the float can move freely and is shielded from incoming liquid by an internal baffle. Overall valve dimensions are shown in Figure 2. The valve is typically mounted to the vessel by a flange on the end of a 3" pipe.

Figure 2: Dimensions

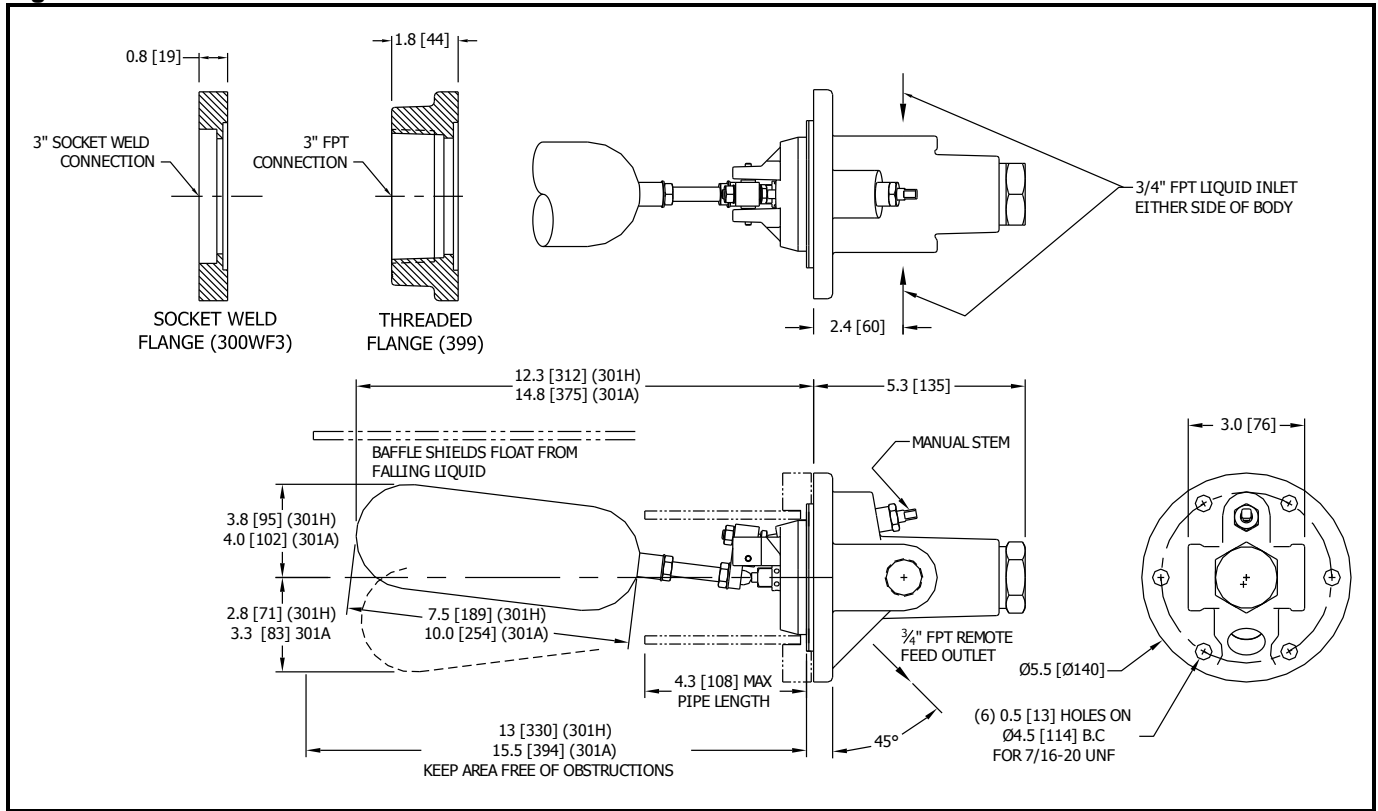

A typical installation arrangement is shown in Figure 3. Notice the optional shut-off solenoid in the liquid supply line. When the refrigeration load is greatly reduced on an individual air unit, or if fans are shut off, it is advisable to close the liquid line solenoid ahead of the float valve in order to stop liquid feed. Otherwise the body of liquid in the surge drum will flow down into the coil and the float valve will continue feeding, thus filling the coil with liquid refrigerant. Room thermostats can be used to stop liquid feed to the evaporators.

Figure 3: Typical Installation

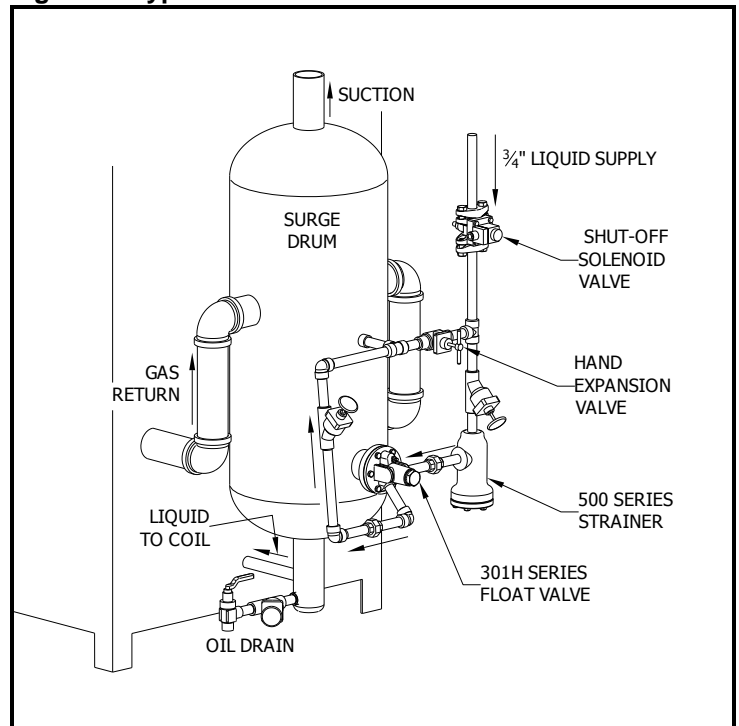

REPLACEMENT PARTS

Basic replacement parts are shown in Figure 4. When contacting Phillips for replacement parts, have the complete valve model and serial number (shown on the valve nameplate) available to ensure you receive the correct components. For example: 301HF-NZZ is a complete model number, and 990105 is a complete serial number.

Figure 4: Replacement Parts

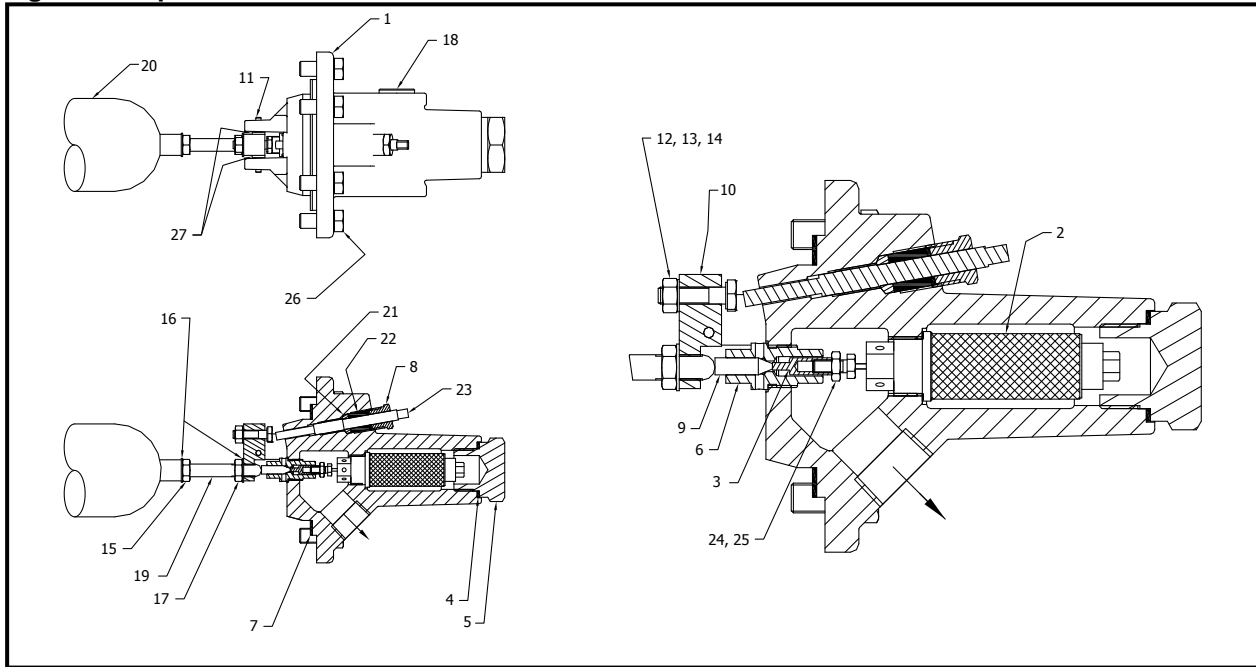

Table 1: Replacement Parts

	Description	301H	301A
1	Valve Body	301-VB	301-VB
2	Cartridge*	355	355
3	Pusher	358	358
4	Gasket*	365	365
5	Access Plug	363	363
6	Boss	307B	307B
7	Gasket	326	326
8	Gland	8	8
9	Cam Needle	314	314
10	Float Block	315R	315R
11	Lever Pin	11	11
12	Adjusting Screw	369A	369A
13	Nut	324	324
14	Lock Washer	55	55
15	Nut	88	88
16	Lock Washer (2)	55A	55A
17	Nut	87	87
18	Pipe Plug	90P	90P
19	Float Rod	343H	343H
20	Float Ball (Ammonia)	370M	370A
	Float Ball (Halocarbon)	370MF	370AF
21	Retainer	776	776
22	Packing Ring	775	775
23	Stem	377	377
24	Hex Nut	359	359
25	Hex Head Screw	357	357
26	Hex Head Cap Screws (6)	325	325
27	Spacers	11S	11S
-	SW Mounting Flange (Figure 2)	300WF3	300WF3
-	Thrd. Mounting Flange (Figure 2)	399	399
-	*Spare Parts Kit (Includes items 2 & 4) Specify orifice diameter when ordering	K355	K355

SERVICE INSTRUCTIONS

Refrigeration systems should only be serviced by a qualified technician. Always observe proper safety procedures.

Changing the Cartridge (Needle & Seat)

When wear of the needle and seat justifies replacement, it is recommended that a completely new cartridge be obtained. These are assembled and tested at the factory for pressure tightness. Cartridge removal for replacement or cleaning is accomplished as follows.

1. Shut off the hand valve in the liquid line and let the compressor run until the liquid line is completely empty. If the evaporator has been flooding badly, pump it down until the liquid level is below the float valve.

(Continued on next page)

2. Turn the float valve manual stem into the valve until firm. **DO NOT USE A HEAVY WRENCH.** The manual stem bears against the float block and seats the cam needle. This isolates the cartridge chamber without requiring a full pump down of the vessel.
3. Close the hand valve in the remote feed line.
4. Unscrew the access plug, venting refrigerant as necessary. Unscrew the cartridge by grasping it by the square shank (Figure 5).
5. The pusher assembly is now accessible for inspection and replacement if it shows signs of wear on the sliding surfaces. The pusher assembly should slide freely on the boss.

Figure 5: Cartridge Removal

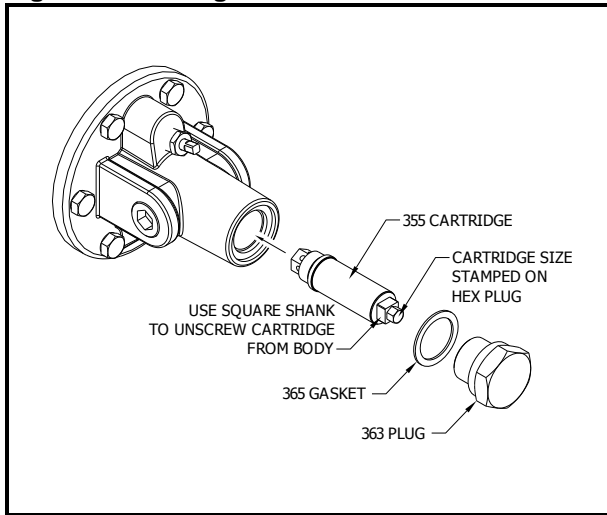

6. If the pusher assembly must be replaced, carefully note the adjustment of the old pusher to ensure proper needle movement after reassembly (Figure 6). The overall length of the pusher should be about 1.30" (33 mm). This should provide about 3/32" (2 mm) cartridge movement after reassembly.
7. Install new parts in the valve, and tighten the new cartridge firmly. Replace the access plug using a new gasket.
8. Back the manual stem out fully. The valve is now ready to be put back in service.

Replacing parts other than the Cartridge and Pusher

To replace parts other than the cartridge and pusher, the evaporator must be fully evacuated and the valve removed from the vessel. Figure 7 shows proper movement of float rod when the rod is correctly threaded into the float block and locknut (87, 55A) is tightened.

Figure 6: Pusher Adjustment

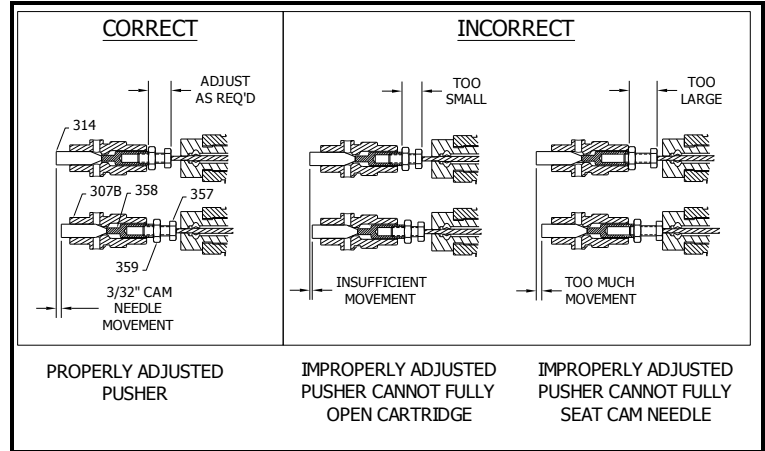
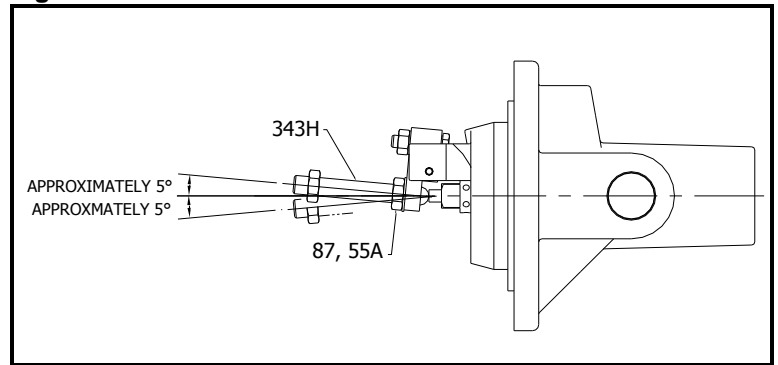

Figure 7: Rod Movement



TROUBLESHOOTING

Problem: Valve overfeeds, flooding the vessel.

Causes/Solutions:

- Cartridge worn, will not shut off properly. Replace cartridge.
- Pusher assembly worn/jammed, will not allow cartridge to close. Replace pusher assembly.
- Float ball developed leak, will not allow float rod to rise. Confirm leak by immersing ball in warm water and observing bubbles. Replace float ball.

Problem: Valve underfeeds, starving the vessel.

Causes/Solutions:

- Pusher assembly worn/jammed, will not allow cartridge to open. Replace pusher assembly.

Problem: Back-seating arrangement does not operate correctly.

Causes/Solutions:

- Parts worn or out of adjustment. Vessel must be pumped down for servicing. With manual stem backed-out 1/4-turn from full inward, adjusting screw (369A) should cause cam needle to fully seat. Fully backed-out manual stem should allow float to rise and close cartridge.