



Capacity controller EKC 331T

Introduction

Application

The controller is used for capacity regulation of compressors or condensers in small refrigerating systems. Regulation can be carried out with up to four identical capacity steps.

Advantages

- Patented neutral zone regulation
- Sequential or cyclic operation

Functions

- Regulation
Regulation with up to four relay outputs can be carried out. Regulation takes place with a set reference which is compared to a signal from a pressure transmitter or a temperature sensor.
- Relay module
It is possible to use the controller as relay module, so that the relays are cut in or out by means of an external voltage signal.
- Alarmfunction
A relay becomes activated when the set alarm limits are exceeded.
- Digital input
The digital input can be used for:
 - night operation where the suction pressure is raised
 - heat recovery where the condensing pressure is raised
 - external start/stop of the regulation.
 - Monitoring of safety circuit
- Possibility of data communication

Display

A signal from a pressure transmitter will always be converted and shown as a temperature value. Settings are made as for temperature values.

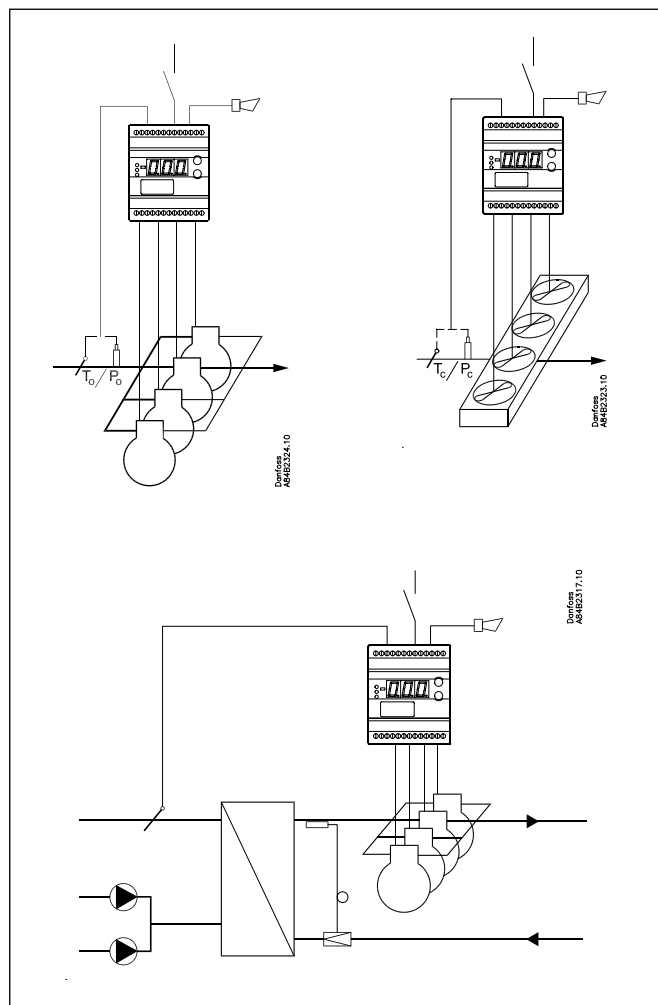

Function

Capacity regulation

The cut-in capacity is controlled by signals from the connected pressure transmitter (temperature sensor) and the set reference. Outside the reference a neutral zone is set where the capacity will neither be cut in nor out.

Outside the neutral zone (in the hatched areas named +zone and -zone) the capacity will be cut in or out if the regulation registers a change of pressure (the temperature) "away" from the neutral zone. Cutin and cutout will take place with the set time delays. If the pressure (the temperature) however "approaches" the neutral zone, the controller will make no changes of the cut-in capacity.

If regulation takes place outside the hatched area (named ++zone and --zone), changes of the cut-in capacity will occur somewhat faster than if it were in the hatched area.

Cutin of steps can be defined for either sequential or cyclic operation.

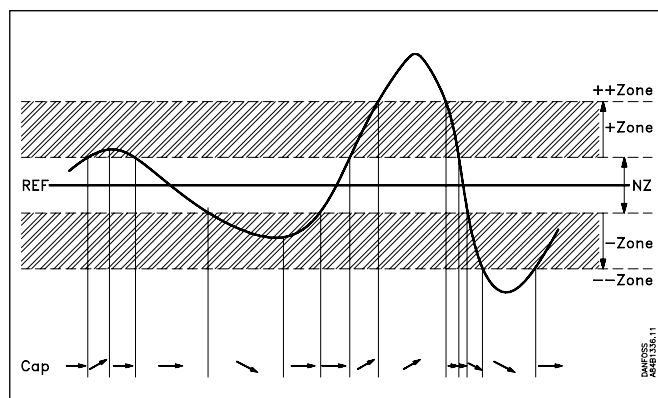

Sequential

The relays are here cut in in sequence – first relay number 1, then 2, etc.

Cutout takes place in the opposite sequence, i.e. the last cut-in relay will be cut out first.

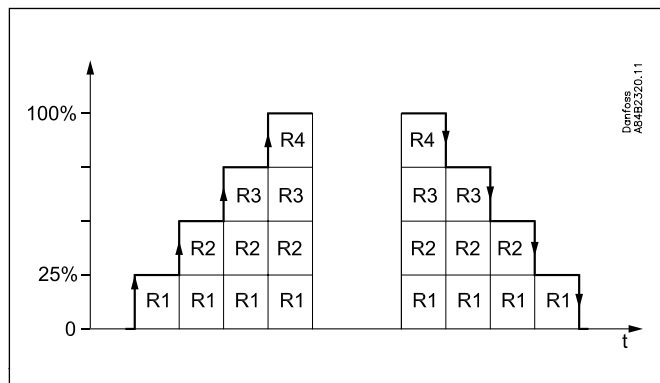

Cyclic

The relays are coupled here so that the operating time of the individual relays will become equalised.

At each cutin the regulation scans the individual relays' timer, cutting in the relay with least time on it.

At each cutout a similar thing happens. Here the relay is cut out that has most hours on the timer.

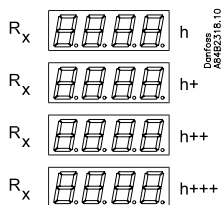

Rx = random relay
h = number of hours

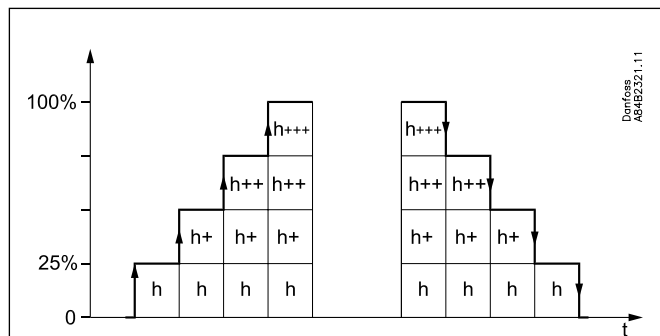

If capacity regulation is carried out on two compressors with one unloader each, the following function can be used:

Relays 1 and 3 are connected to the compressor motor.

Relays 2 and 4 are connected to the unloaders.

Relays 1 and 3 will operate in such a way that the operating time for the two relays will become equalised.

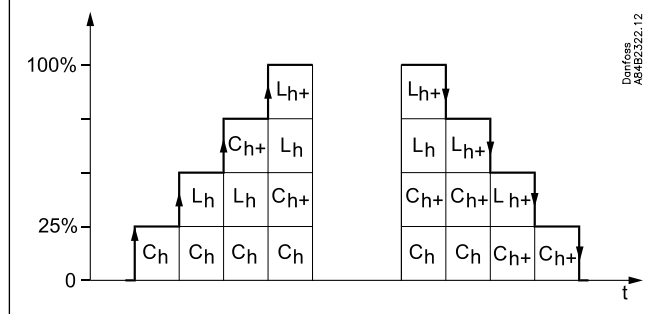
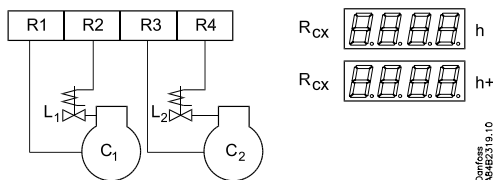

C = compressor, L = Unloader

Relay module

The controller can also be used as a relay module where the relays in the module are operated by the received voltage signal. The signal must be connected to terminal 15-16.

Depending on the definition of the signal and the number of relays used, the relays will be "distributed" over the signal.

A hysteresis at the individual coupling points will ensure that the relay will not cut in or out when not required.

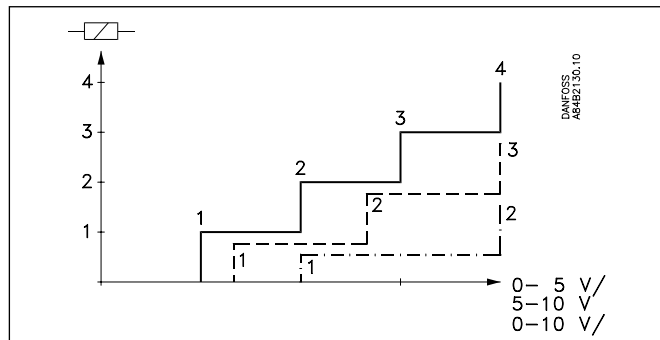

Suvey of functions

Function	Parameter	Parameter by operation via data communication
Normal display		
Normally the signal from the pressure transmitter/temperature sensor is shown If the controller is used as relay module, U _{in} will appear on the display.		Pressure / Temp°C
Pressure regulation		Reference
Regulation setpoint Regulation is based on the set value. A change of the set value can be limited/fixed by means of the settings in r02 and r03. (Push both buttons simultaneously to set the menu.)	-	Set point°C
Neutral zone There is a neutral zone around the reference. See also page 2.	r01	Neutral zone
Reference The set reference may be displaced with a fixed value when a signal is received at the DI input. Regulation will then be based on the set point plus the value set here. (Cf. also Definition of DI input).	r13	Offset K
The total reference can be seen when you push the lower of the two buttons	-	Reference
Set point limitation The controller's setting range for the set point can be narrowed down, so that you cannot accidentally set a too high or too low value - that may result in damage to the system. With these settings the setpoint can only be set between the two values. Max. permissible setpoint value. Min. permissible setpoint value.		
	r02	Max. set point
	r03	Min. set point
Correction of temperature measurement An offset adjustment of the registered temperature can be made. The function is used if correction for a too long sensor cable has to be made.	r04	Adjust sensor
Unit Here you can select whether the display is to indicate temperatures in °C or in °F. Setting = "C-b" will give °C. Setting = "F-P" will give °F.	r05	Unit 0: °C 1: °F (In AKM only °C is used, whatever the setting)
Capacity		Capacity
Running time To prevent frequent start/stop, values have to be set for how the relays are to cut in and out.		
Min. ON time for relays.	c01	Min.ON time
Min. time period between cutin of same relay.	c07	Min recycle time
Coupling Cutin and cutout can take place in three ways: 1. Sequential: First relay 1 cuts in, then relay 2, etc. Cutout takes place in the opposite sequence. ("First in, last out"). 2. Cyclic: An automatic operating time equalisation is arranged here, so that all steps will have the same operating time. (The relay with the fewest number of operating hours cuts in or out before the others) (Or put differently: "First in, last out"). 3. Cyclic with unloader: The function can only be used when there are two compressors with one unloader each. The cyclic operation is performed on relays 1 and 3. The unloaders are mounted on relays 2 and 4 (relays 1 and 2 belong to the first compressor, relays 3 and 4 to the other). The above mentioned "Min. On-time" and "Min. recycle time" are not used for unloaders. In connection with cutout, the two unloaders are cut out before the compressors are cut out.	c08	Step mode
Unloaders' cutin and cutout mode (Only in connection with cutin/cutout mode 3. See above). The relays for the two unloaders can be set to switch on when more capacity is required (setting = no), or they can switch off when more capacity is called for (setting = nc).	c09	Unloader (switch on = 0) (switch off = 1)

Setting for neutral zone regulation		
Regulation band under the neutral zonen	c10	+ Zone K
Time delay between step cut-ins in the regulation band over the neutral zone	c11	+ Zone m
Time delay between step cut-ins in the regulation band over the "+Zone band".	c12	+ + Zone s
Regulation band over the neutral zone	c13	- Zone K
Time delay between step cut-outs in the regulation band under the neutral zone	c14	- Zone m
Time delay between step cut-outs in the regulation band under the "-Zone band"	c15	-- Zone s
Alarm		Alarm settings
The controller can give alarm in different situations. When there is an alarm all the light-emitting diodes (LED) will flash on the controller front panel, and the alarm relay will cut in.		
Upper deviation Here you set when the alarm at high temperature/pressure is to enter into effect. The value is set as an absolute value. See also emergency procedure page 7.	A10	Max. press / Temp.
Lower deviation Here you set when the alarm at low temperature/pressure is to enter into effect. The value is set as an absolute value. See also emergency procedure page 7.	A11	Min. press / Temp.
Alarm delay If one of the two limit values is exceeded, a timer function will commence. The alarm will not become active until the set time delay has been passed. The time delay is set in minutes.	A03	Alarm delay
Give the top button a brief push to zeroset the alarm and to have the message shown on the display.		Reset alarm The function zerosets all alarms when set in pos. ON.
		Alarm relay Here you can read the status of the alarm relay. (ON indicates operation with alarm).
		With data communication the importance of the individual alarms can be defined. Setting is carried out in the "Alarm destinations" menu.
Miscellaneous		Miscellaneous
External signal Here you set the signal to be connected to the controller. 0: No signal/regulation stopped (display will then show OFF) 1: 4-20 mA from pressure transmitter for compressor regulation 2: 4-20 mA from pressure transmitter for condenser regulation 3: Pressure transmitter type AKS 32R for compressor regulation 4: Pressure transmitter type AKS 32R for condenser regulation 5: 0-10 V from other regulation 6: 0-5 V from other regulation 7: 5-10 V from other regulation 8: Pt1000 ohm temperature sensor for compressor regulation 9: Pt1000 ohm temperature sensor for condenser regulation 10: PTC1000 ohm temperature sensor for compressor regulation 11: PTC1000 ohm temperature sensor for condenser regulation	o10	Application mode
Number of relays Depending on the application, up to four relays may be used. This number must be set in the controller. (The relays are always used in numerical sequence).	o19	Number of steps
Pressure transmitter's working range Depending on the pressure, a pressure transmitter with a given working range is used. This working range must be set in the controller (e.g.: -1 to 12 bar The values must be set in bar if display in °C has been selected. And in psig, if °F has been selected. Min. value Max. value		If the two values are to be set from the AKM programme, they must be set in bar.
	o20	Min. trans. press
	o21	Max trans. press

<p>Use of DI input The digital input can be connected to a contact function, and the contact can now be used for one of the following functions: Setting / function: 0: DI input not used 1: Regulation reference displaced when contact is cut in 2: Regulation is started and stopped when the contact is cut in and out, respectively. 3: Monitoring of the compressor's safety circuit. When the contact on the DI input cuts out, all relay outputs will immediately be cut out. At the same time the alarm will sound.</p>	o22	Di input control
<p>Operating hours The operating hours for the four relays can be read in the following menus. The read value is multiplied by 10 to obtain the number of hours. On reaching 999 hours the counter stops and must now be reset to, say, 0. There will be no alarm or error message for counter overflow.</p>		(In the AKM display the hour number has not been multiplied)
<p>Value for relay number 1</p>	o23	DO 1 run hour
<p>Value for relay number 2</p>	o24	DO 2 run hour
<p>Value for relay number 3</p>	o25	DO 3 run hour
<p>Value for relay number 4</p>	o26	DO 4 run hour
<p>Refrigerant setting Before refrigeration is started, the refrigeration must be defined. You may choose between the following refrigerants: 1=R12. 2=R22. 3=R134a. 4=R502. 5=R717. 6=R13. 7=R13b1. 8=R23. 9=R500. 10=R503. 11=R114. 12=R142b. 13=User defined. 14=R32. 15=R227. 16=R401A. 17=R507. 18=R402A. 19=R404A. 20=R407C. 21=R407A. 22=R407B. 23=R410A. 24=R170. 25=R290. 26=R600. 27=R600a. 28=R744. 29=R1270. 30=R417A Warning: Wrong selection of refrigerant may cause damage to the compressor.</p>	o30	Refrigerant
<p>Manual control From this menu the relays can be cut in and out manually. OFF gives no override, but a number between 1 and 4 will cut in a corresponding number of relays. Cutins and cutouts always take place from relay number 1. When there is manual operation, the display will show "- - x". Where x is 0 - 4</p>	o18	
<p>Frequency Set the net frequency.</p>	o12	Main freq (50=0, 60=1)
<p>Address If the controller is built into a network with data communication, it must have an address, and the master gateway of the data communication must then know this address. These settings can only be made when a data communication module has been mounted in the controller and the installation of the data communication cable has been completed. This installation is mentioned in a separate document "RC.8A.C".</p>		Following installation of a data communication module, the controller can be operated on a par with the other controllers in ADAP-KOOL® refrigeration controls.
<p>The address is set between 1 and 60</p>	o03	
<p>The address is sent to the gateway when the menu is set in pos. ON</p>	o04	
<p>Access code If the settings in the controller are to be protected by a numerical code, you can set a numerical value between 0 and 100. If not, you can cancel the function with setting OFF.</p>	o05	
		<p>Manual control Only when "Manual control" has been put in pos. ON will it be possible to operate the individual relays: DO relay 1 DO relay 2 DO relay 3 DO relay 4 Alarm relay set When this function is used, the buttons on the controller cannot be used.</p>

Operating status	
The controller goes through some regulating situations where it is just waiting for the next point of the regulation. To make these “why is nothing happening” situations visible, you can see an operating status on the display. Push briefly (1s) the upper button. If there is a status code, it will be shown on the display. The individual status codes have the following meanings	EKC state (0 = regulation)
S2: When the relay is operated, it must be activated for min. x minutes (cf. C01)	2
S5: Renewed cutin of the same relay must not take place more often than every x minutes (cf. C07)	5
S8: The next relay must not cut in until x minutes have elapsed (cf. C11-C12)	8
S9: The next relay must not cut out until x minutes have elapsed (cf. C14-C15)	9
S16: Regulation stopped due to manual operation via o18.	16
PS: Password required. Set password	PS
Alarm messages	Alarms
A1: High temperature alarm (cf. A10)	High temp. alarm
A2: Low temperature alarm (cf. A11)	Low temp. alarm
A11: No refrigerant has been selected (cf. o30)	RFG not selected
A12: Regulation stopped due to interrupted signal on the DI input	DI Alarm
E1: Error in the controller	Controller fault
E2: Control signal outside the range (short-circuited/interrupted)	Out of range

Emergency procedure

If the controller registers irregularities in the registered signals, it will start an emergency procedure:

For compressor regulation:

- If the signal from the temperature sensor/pressure transmitter becomes smaller than expected, the controller will continue operating with the average capacity that has been cut in during the past 60 minutes. This cut-in capacity will gradually decline as time passes.
- If the signal becomes smaller than the set value of A11, the capacity will instantly be cut out.

For condenser regulation:

- If the signal from the temperature sensor/pressure transmitter becomes smaller than expected, or if the condensing pressure becomes bigger than the set value of A10, the entire capacity will instantly be cut in.

Operation

Display

The values will be shown with three digits, and with a setting you can determine whether the temperature are to be shown in °C or in °F.

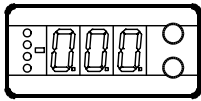

Light-emitting diodes (LED) on front panel

There are four LED's on the front panel which will light up when the relays are operated.

All LED's will flash if there is an error in the regulation. In this situation you can upload the error code on the display and cancel the alarm by pushing the top button briefly.

The controller can give the following messages:		
E1	Error message	Errors in the controller
E2		Regulation out of range or control signal is defect.
A1	Alarm message	High pressure alarm
A2		Low pressure alarm
A11		No refrigerant selected
A12		Regulation stopped due to interrupted signal on the DI input

The buttons

When you want to change a setting, the two buttons will give you a higher or lower value depending on the button you are pushing. But before you change the value, you must have access to the menu. You obtain this by pushing the upper button for a couple of seconds - you will then enter the column with parameter codes. Find the parameter code you want to change and push the two buttons simultaneously. When you have changed the value, save the new value by once more pushing the two buttons simultaneously.

- Gives access to the menu (or cutout an alarm)
- Gives access to changes
- Saves a change

Examples of operations

Set the regulation's set point

1. Push the two buttons simultaneously
2. Push one of the buttons and select the new value
3. Push both buttons again to conclude the setting

Set one of the other menus

1. Push the upper button until a parameter is shown
2. Push one of the buttons and find the parameter you want to change
3. Push both buttons simultaneously until the parameter value is shown
4. Push one of the buttons and select the new value
5. Push both buttons again to conclude the setting

Menu survey

SW: 1.1x

Function	Parameter	Min.	Max.	Factory setting
Normal display				
Shows the signal from the temperature sensor / pressure transmitter	-		°C	
Reference				
Set the regulation's set point	-	-60 °C	170 °C	3
Neutral zone	r01	0.1 K	20 K	4.0
Max. limitation of set point setting	r02	-60 °C	170 °C	50
Min. limitation of set point setting	r03	-60 °C	50 °C	-60
Correction of signal from the sensor	r04	-20 K	20 K	0.0
Select unit (C-b=°C and F-P= °F)	r05	C-b	F-P	C-b
Reference displacement by signal at DI input	r13	-50 K	50 K	0
Capacity				
Min. ON time for relays	c01	0 min.	30 min	2
Min. time period between cutins of same relay	c07	0 min.	60 min.	4
Definition of regulation mode 1: Sequential (step mode / FILO) 2: Cyclic (step mode / FIFO) 3: Compressor with unloader	c08	1	3	1
If the regulation mode 3 has been selected, the relays for the unloaders can be defined to: no: Cut in when more capacity is required nc: Cut out when more capacity is required	c09	no	nc	no
Regulation parameter for + Zone	c10	0.1 K	20 K	3
Regulation parameter for + Zone min.	c11	0.1 min.	60 min.	2
Regulation parameter for ++ Zone seconds	c12	1 s	180 s	30
Regulation parameter for - Zone	c13	0 K	20 K	3
Regulation parameter for - Zone min.	c14	0.1 min.	60 min.	1
Regulation parameter for -- Zone seconds	c15	1 s	180 s	30
Alarm				
Alarm time delay	A03	1 min.	90 min.	30
Upper alarm limit (absolute value)	A10	-60 °C	170 °C	50
Lower alarm limit (absolute value)	A11	-60 °C	50 °C	-60
Miscellaneous				
Controllers address	o03*	1	60	0
On/off switch (service-pin message)	o04*	-	-	-
Access code	o05	off(-1)	100	-
Define input signal and application: 0: no signal / regulation stopped 1: 4-20 mA pressure transmitter - compressor reg. 2: 4-20 mA pressure transmitter - condenser reg. 3: AKS 32R pressure transmitter - compressor reg. 4: AKS 32R pressure transmitter - condenser reg. 5: 0 - 10V relay module 6: 0 - 5 V relay module 7: 5 - 10V relay module 8: Pt 1000 ohm sensor - compressor reg. 9: Pt 1000 ohm sensor - condenser reg. 10: PTC 1000 ohm sensor - compressor reg. 11: PTC 1000 ohm sensor - condenser reg.	o10	0	11	0
Set supply voltage frequency	o12	50 Hz	60 Hz	50
Manual operation with "x" relays	o18	0	4	0
Define number of relay outputs	o19	1	4	4
Pressure transmitter's working range - min. value	o20	-1 bar	0 bar	-1
Pressure transmitter's working range - max. value	o21	1 bar	40 bar	12

Continued

Define DI input: 0: not used 1: Contact displaces reference 2: Contact starts and stops regulation 3: Interrupted contact will cut out the capacity, and alarm will be given.	o22	0	3	0
Operating hours of relay 1 (value times 10)	o23	0 h	999 h	0
Operating hours of relay 2 (value times 10)	o24	0 h	999 h	0
Operating hours of relay 3 (value times 10)	o25	0 h	999 h	0
Operating hours of relay 4 (value times 10)	o26	0 h	999 h	0
Setting of refrigerant 1=R12. 2=R22. 3=R134a. 4=R502. 5=R717. 6=R13. 7=R13b1. 8=R23. 9=R500. 10=R503. 11=R114. 12=R142b. 13=User defined. 14=R32. 15=R227. 16=R401A. 17=R507. 18=R402A. 19=R404A. 20=R407C. 21=R407A. 22=R407B. 23=R410A. 24=R170. 25=R290. 26=R600. 27=R600a. 28=R744. 29=R1270. 30=R417A	o30	0	30	0

*) This setting will only be possible if a data communication module has been installed in the controller.

Factory setting

If you need to return to the factory-set values, it can be done in this way:

- Cut out the supply voltage to the controller
- Keep both buttons depressed at the same time as you reconnect the supply voltage

Data

Supply voltage	230 V a.c. +/-15% 50/60 Hz, 5 VA	
Input signal	Pressure transmitter*) with 4-20 mA or temperature sensor Pt 1000 ohm or temperature sensor PTC 1000 ohm or voltage signal (0 - 5 V, 0 - 10 V or 5 - 10 V)	
	Digital input to external contact function	
Relay output	4 pcs. SPST	AC-1: 4 A (ohmic) AC-15: 3 A (inductive)
Alarmrelay	1 pcs. SPST	AC-1: 4 A (ohmic) AC-15: 1 A (inductive)
Data communication	Possible to connect a data communication module	
Environments	-10 - 55°C, during operation	
	-40 - 70°C, during transport	
	20 - 80% Rh, not condensed	
	No shock influence / vibrations	
Enclosure	IP 20	
Weight	300 g	
Mounting	DIN rail	
Display	LED, 3 digits	
Terminals	max. 2.5 mm ² multicore	
Approvals	EU Low voltage Directive and EMC demands re CE-marking complied with. LVD-tested acc. to EN 60730-1 and EN 60730-2-9 EMC-tested acc. to EN50081-1 and EN 50082-2	

*) Pressure transmitter

As pressure transmitter can be used AKS 3000 or AKS 33 (AKS 33 has a higher accuracy than AKS 3000).

It is also possible to use an AKS 32R. This pressure transmitter is only supplied in large quantities as per arrangement with Danfoss. Please refer to catalogue RK0YG...

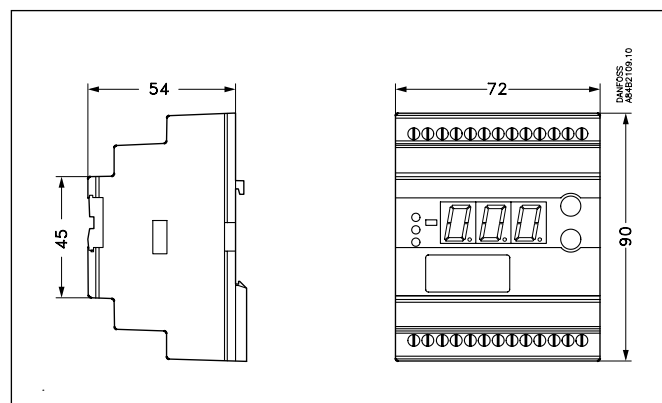

Ordering

Type	Function	Code No.
EKC 331T	Capacity controller	084B7105
EKA 173	Data communication module (accessories), (FTT 10 module)	084B7092
EKA 175	Data communication module (accessories), (RS 485 module)	084B7093

Connections

Necessary connections

Terminals:

- 25-26 Supply voltage 230 V a.c.
- 3- 10 Relay connections no. 1, 2, 3 and 4
- 12-13 Alarm relay
There is connection between 12 and 13 in alarm situations and when the controller is dead

Control signal (see also o10)

Either terminals:

- 14-16 Voltage signal from AKS 32R
- or
- 17-18 Current signal from AKS 3000 or AKS 33
- or
- 15-16 Sensor signal from AKS 21, AKS 12 or EKS 111
- or
- 15-16 Voltage signal from an other regulation.

External contact function, if applicable

- 19-20 Contact function for displacement of reference or start/stop of the regulation or for monitoring of safety circuit.

Data communication, if applicable

- 21-22 Mount only, if a data communication module has been mounted.
It is important that the installation of the data communication cable be done correctly. Cf. separate literature No. RC8AC...

