



Stop valves,
type SVA-DL & SVA-DH 250 - 300

Contents

	Page
Introduction.....	3
Features.....	3
Design	4
Technical data	5
Function	6
Material specification:	
SVA-DL 250 - 300.....	7
SVA-DH 250 - 300	8
Connections.....	9
Dimensions and weights.....	9
Ordering	10
Code numbers.....	10

Introduction



SVA-DL and SVA-DH are angleway stop valves designed to meet all industrial refrigeration application requirements.

SVA-DL (**Delta pressure Low**) is designed with a restriction in the opening function. High differential pressure can be applied from the side port and reduced pressure can be applied from bottom port. SVA-DL is a two-step valve for pressure relief.

SVA-DH (**Delta pressure High**) is designed without restriction in the opening function. As a result of its balanced design this valve is able to open at all differential pressures with limited torque.

The angleway stop valves are carefully designed to give favourable flow conditions. Easy to dismantle for inspection and repair.

Both SVA-DL & DH stop valves have internal backseating enabling the spindle seal to be replaced with the valve still under pressure.

The valves are designed to give favourable flow characteristics and are easy to dismantle for servicing. The valve cone is designed to ensure perfect closing.

Features

- Applicable to all common refrigerants including R 717 and non corrosive gases/ liquids dependent on sealing material compatibility
- Optional accessories:
 - Heavy duty industrial handwheel for frequent operation
 - Vented cap for infrequent operation
- Available in angleway version with extended bonnet for insulated systems
- The valve caps can be wire-sealed, to prevent operation by unauthorised persons.
- Internal PTFE backseating
- The bonnet is suitable for installation in insulated low temperature applications.
- The housing and bonnet are made from low temperature steel in accordance with the requirements of the Pressure Equipment Directive and other international classification authorities
- For an updated list of certifications on the products please contact your local Danfoss Sales Company

Design

Connections

Available with the following connections:
 Butt-weld DIN 2448
 Butt-weld ANSI B 36.10
 - DN250: Schedule 40
 - DN300: STD

Housing and bonnet

Made from special, cold-resistant steel approved for low temperature operations.

Bolts

Stainless steel, Quality A2-70

Valve cone assembly

The valve cone assembly can be turned on the spindle, thus there is no friction between cone and seat when the valve is opened and closed. A Teflon tightening ring provides perfect sealing at a minimum closing torque.

Spindle

Made of polished stainless steel, ideal for O-ring sealing.

Packing gland

The packing gland comprises a spring loaded seal packing which ensures perfect tightness in the range: -60/+150°C (-76/+302°F). Furthermore, the packing glands incorporate a scraper ring to prevent the penetration of dirt and ice.

Marking

Each valve type is clearly marked with type, size and performance range.

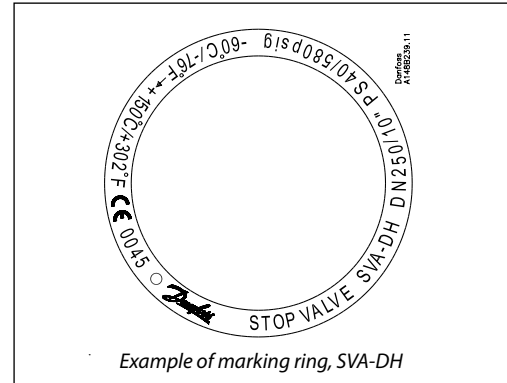

Example of marking ring, SVA-DH

Pressure Equipment Directive (PED)

SVA-DL and DH valves are approved and CE marked in accordance with the Pressure Equipment Directive - 97/23/EC.

For further details / restrictions - see Installation Instruction.



SVA-DL & DH valves		
Nominal bore	DN 250 mm (10 in.)	DN 300 mm (12 in.)
Classified for	Fluid group I	
Category	III	IV

Technical data

Refrigerants

Applicable to all common non-flammable refrigerants including R 717 and non-corrosive gases/liquids dependent on sealing material compatibility.

For further information please see installation instruction for SVA-DL and SVA-DH.

Flammable hydrocarbons are not recommended.

For further information please contact your local Danfoss Sales Company.
Temperature range

SVA-DL and SVA-DH

-60/+150°C (-76/+302°F)

Pressure range

SVA-DL and SVA-DH

40 bar g (580 psi g) at -60°C to +60°C (-76°F to +140°F)

36 bar g (522 psi g) at +60°C to +80°C (+140°F to +176°F)

32 bar g (464 psi g) at +80°C to +120°C (+176°F to +248°F)

28 bar g (406 psi g) at +120°C to +150°C (+248°F to +302°F)

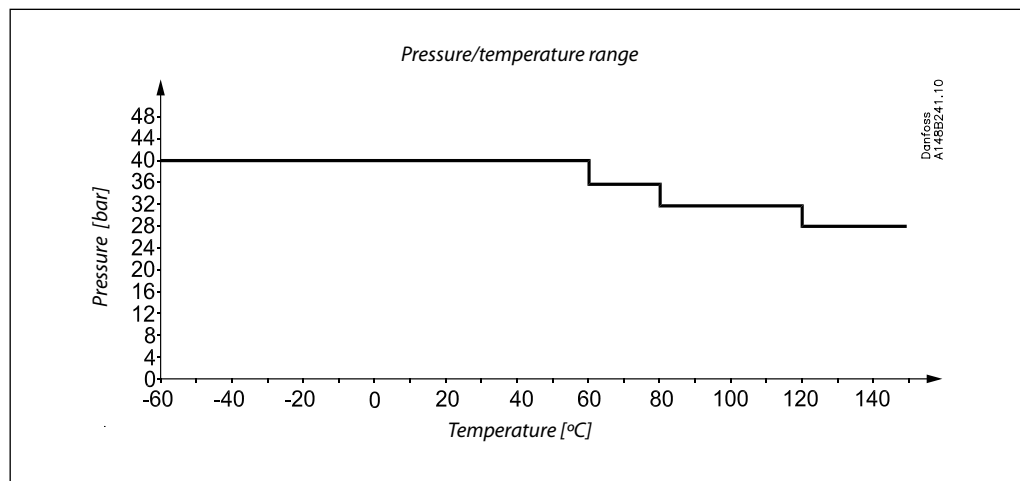

Function

SVA-DL

The SVA-DL stop valve is designed with a restriction in the flow direction (differential pressure). To ensure the most favourable valve performance the flow must be directed from the side port towards the valve cone. Operation of the valve with flow in this direction is made possible by the two-step opening valve cone as illustrated below.

The sketches below give the minimum pressures at which the valve can be operated manually and tightness can be achieved.

SVA-DH

The SVA-DH stop valve is designed without restrictions in either flow direction or differential pressure. Due to the balanced valve cone design the torque required to operate the valve is minimized and the valve can be opened and closed against high pressure with flow in any direction.

Pressure

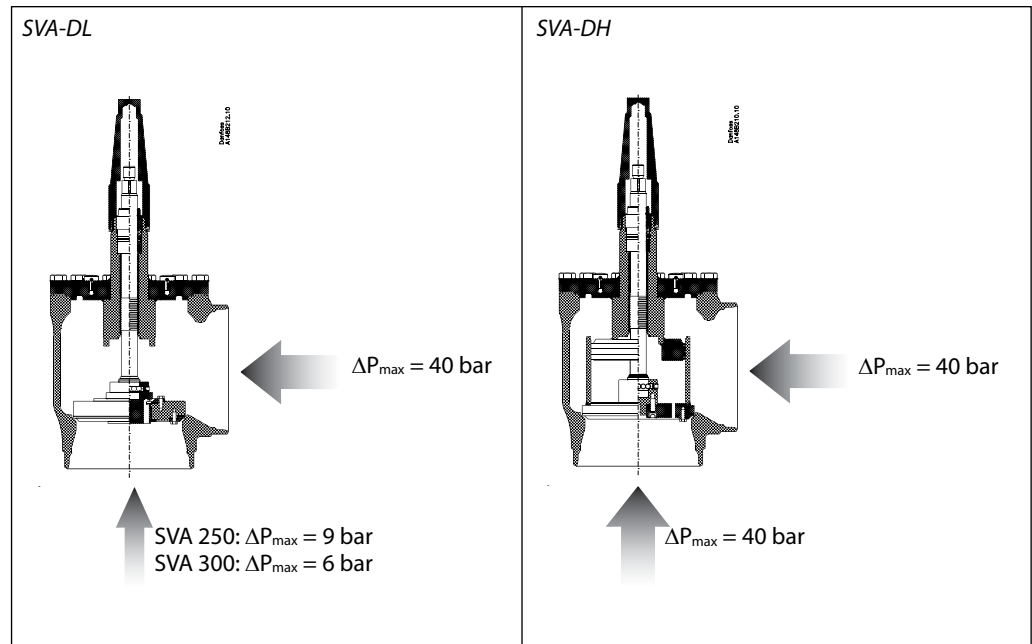

Flow

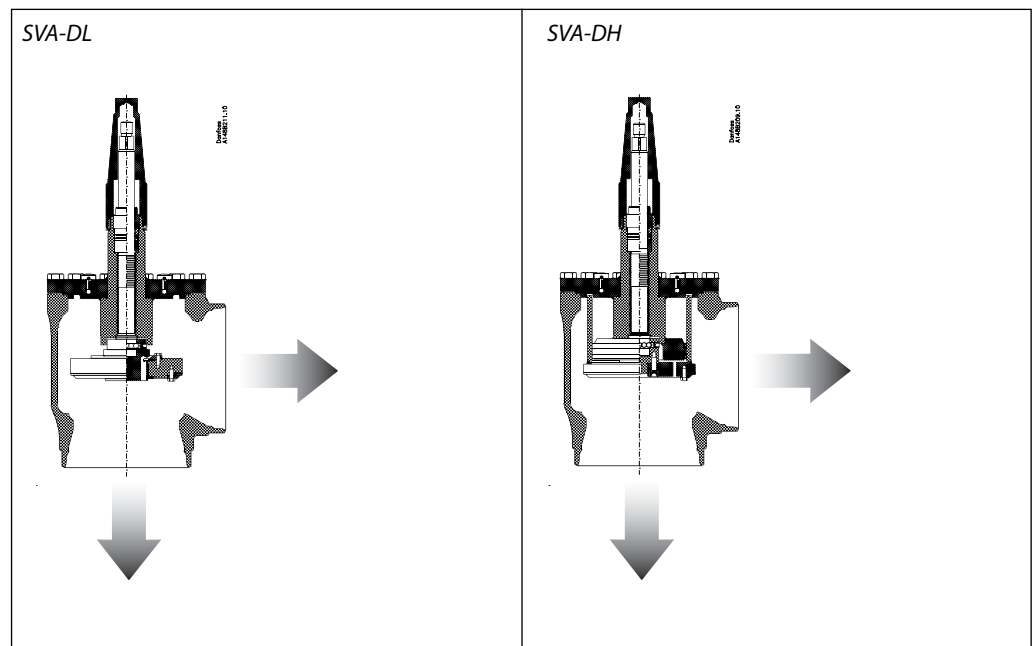

Material specification

SVA-DL 250 - 300

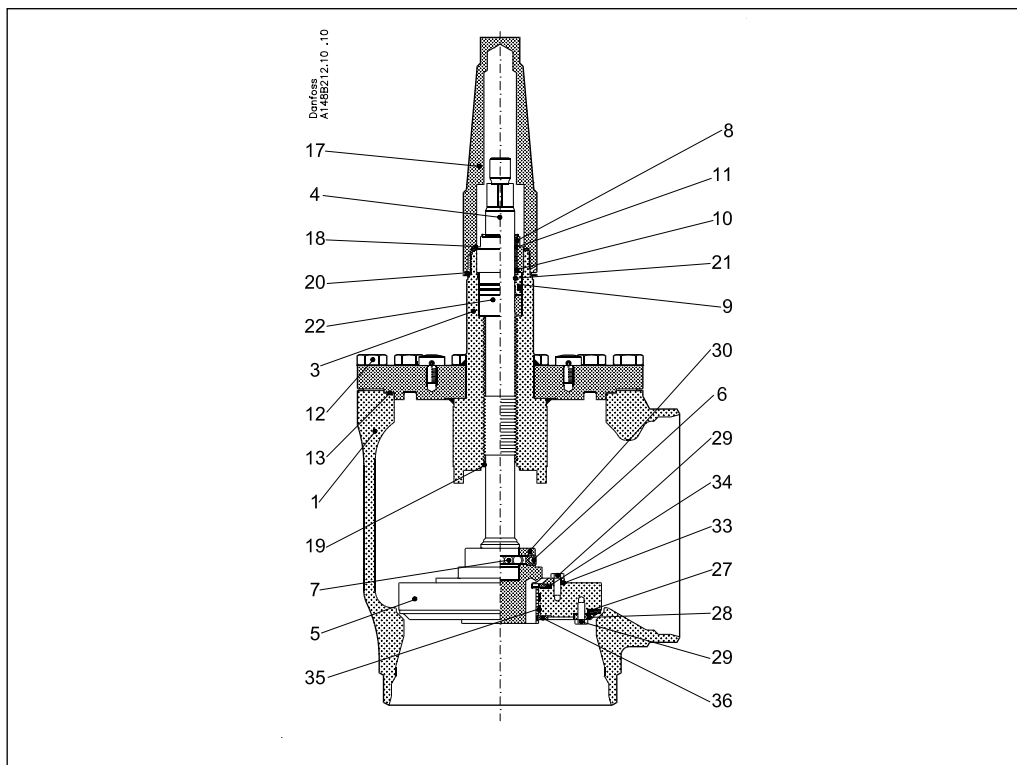

No.	Part	Material	EN	ASTM
1	Housing	Steel	G20Mn5 QT, EN 10213-3	LCC, A352
3	Bonnet	Steel	P275NL1, EN 10028-3 G20Mn5QT EN 10213-3	Grade A, A662 LCC, A352
4	Spindle	Steel	X5CrNi18-10, EN10088	AISI 304
5	Cone	Steel	P275NL1, EN 10028-3	Grade A, A662
6	Set screw	Steel	Quality 8.8	Grade 5
7	Balls	Stainless steel		
8	Packing Gland	Steel	11SMn30	Grade 1213, A29
9	O-ring	Cloroprene (Neoprene)	CR	CR
10	U-sleeve sealing	Teflon (PTFE) + Stainless steel		
11	O-ring	Cloroprene (Neoprene)	CR	CR
12	Bolts	Stainless steel	A2-70	Type 308
13	Gasket	Fiber, Non-asbestos		
14	Handwheel	Steel		
15	Washer	Stainless steel		
16	Lock nut	Stainless steel+nylon		
17	Cap	Aluminium	AlMgSi1	
18	Gasket for cap	Nylon (PA 6)		
19	Soft backseat	Teflon (PTFE)		
20	Identification ring	Stainless steel		
21	Wear ring	Teflon (PTFE)		
22	Guide for spindle	Steel	11SMn30	Grade1213, A29
27	Gasket	Teflon (PTFE)		
28	Front for valve cone	Steel	S235JRG2, EN10025	Grade C, A283
29	Bolts	Steel	Quality 8.8	Grade 5
30	Insert, valve cone	Spheroidal graphite cast iron	EN-GJS-250	Class 40B
31	Lifting eye bolts	Steel		
33	Backing for valve cone	Steel	S235JRG2, EN10025	Grade C, A283
34	Gasket	Teflon (PTFE)		
35	Wear ring	Teflon (PTFE)		
36	Retaining ring	Spring steel		

Material specification

SVA-DH 250 - 300

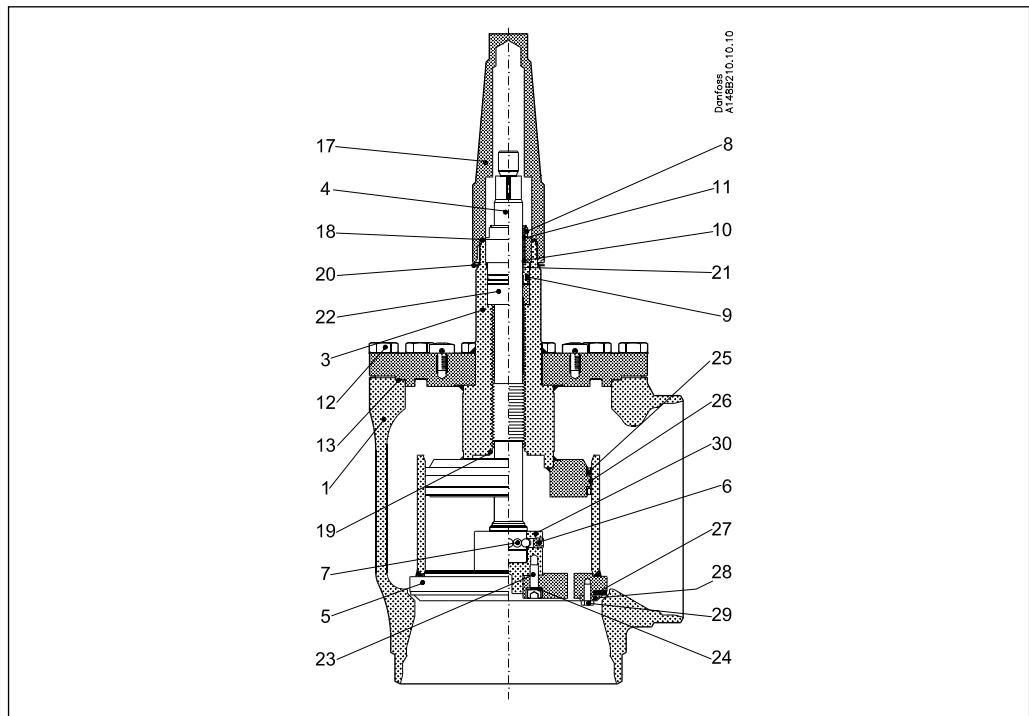

No.	Part	Material	EN	ASTM
1	Housing	Steel	G20Mn5 QT, EN 10213-3	LCC, A352
3	Bonnet	Steel	P275NL1, EN 10028-3 G20Mn5 QT, EN 10213-3	Grade A, A662 LCC, A352
4	Spindle	Steel	X5CrNi18-10 DIN 17440	
5	Cone	Steel	P275NL1, EN 10028-3	Grade A, A662
6	Set screw	Steel	Quality 8.8	Grade 5
7	Balls	Stainless steel		
8	Packing Gland	Steel	11SMn30	Grade 1213, A29
9	O-ring	Cloroprene (Neoprene)	CR	CR
10	U-sleeve sealing	Teflon (PTFE) + Stainless steel		
11	O-ring	Cloroprene (Neoprene)	CR	CR
12	Bolts	Stainless steel	A2-70	Type 308
13	Gasket	Fiber, Non-asbestos		
14	Handwheel	Steel		
15	Washer	Stainless steel		
16	Lock nut	Stainless steel+nylon		
17	Cap	Aluminium	AlMgSi1	
18	Gasket for cap	Nylon (PA 6)		
19	Soft backseat	Teflon (PTFE)		
20	Identification ring	Stainless steel		
21	Wear ring	Teflon (PTFE)		
22	Guide for spindle	Steel	11SMn30	Grade 1213, A29
23	Bolts	Steel	Quality 8.8	Grade 5
24	Washer	Steel		
25	U-sleeve sealing	Teflon (PTFE) +Stainless steel		
26	Wear ring	Teflon (PTFE)		
27	Gasket	Teflon (PTFE)		
28	Front for valve cone	Steel	S235JRG2, EN10025	Grade C, A283
29	Bolts	Steel	Quality 8.8	Grade 5
30	Insert, valve cone	Spheroidal graphite cast iron	EN-GJS-250	Class 40B
31	Lifting eye bolts	Steel		

Connections

DIN

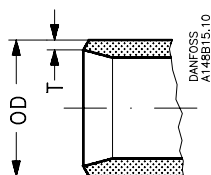

Size mm	Size in.	OD mm	T mm	OD in.	T in.
<i>Welding DIN (2448)</i>					
250	10	273	6.3	10.75	0.25
300	12	323.9	7.1	12.75	0.28

Type	K_v m ³ /h	C_v Usgal/min
SVA-DH	1405	1630
SVA-DL	1610	1868
SVA-DH	1870	2169
SVA-DL	2082	2415

ANSI

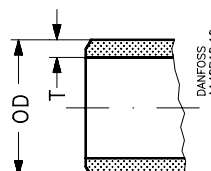

Size mm	Size in.	OD mm	T mm	OD in.	T in.
<i>Welding ANSI (B 36.10)</i>					
250	10	273	6.3	10.75	0.25
300	12	323.9	7.1	12.75	0.28

Type	K_v m ³ /h	C_v Usgal/min
SVA-DH	1405	1630
SVA-DL	1610	1868
SVA-DH	1870	2169
SVA-DL	2082	2415

Dimensions and weights

SVA-DH, SVA-DL 250-300, angleway version

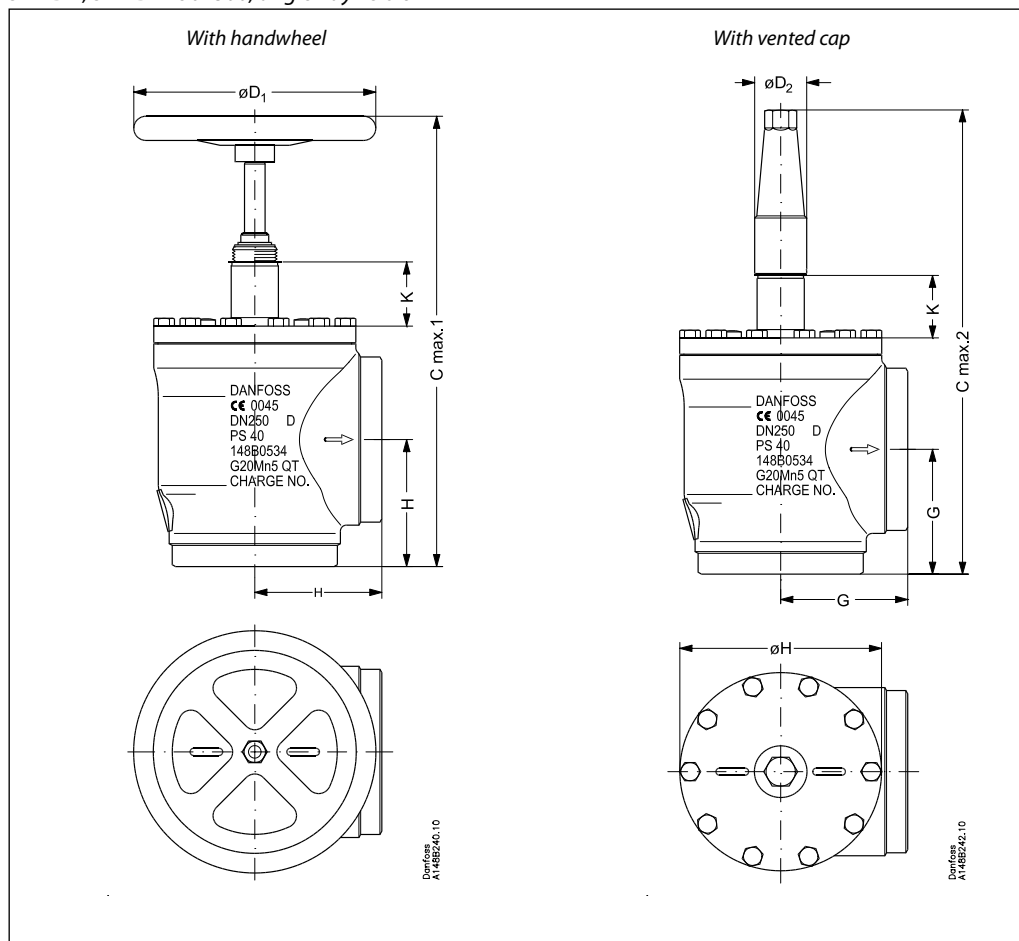

Valve size	K	$C_{max. 1}$	$C_{max. 2}$	G	$\varnothing D_1$	$\varnothing D_2$	$\varnothing H$	Weight
<i>SVA-DL / SVA-DH</i>								
SVA 250	mm	102	745	782	210	400	86	130 kg
SVA (10)	in.	4	29.33	30.79	8.27	15.75	3.39	287 lb
SVA 300	mm	102	852	842	240	500	86	190 kg
SVA (12)	in.	4	33.54	33.14	9.45	19.69	3.39	419 lb

Specified weights are approximate values only

Ordering

The table below can be used to identify the valve required.

Please note that the type codes only serve to identify the valves, some of which may not form part of the standard product range.

For further information please contact your local Danfoss Sales Company.

Type codes

Valve type Nominal size in mm	SVA-DL SVA-DH	Stop valve Stop valve	(Δp Low) (Δp High)	
			Available connections	
			D	A
(Valve size measured on the connection diameter)	250	DN250	X	X
	300	DN300	X	X
Connections	D	Butt weld connection: DIN 2448		
	A	Butt weld connections: ANSI B 36.10 DN250: Schedule 40 DN300: STD		
Other equipment	CAP H-WHEEL	Aluminum cap Steel handweel		

Important!

Where products need to be certified according to specific certification societies or where higher pressures are required, the relevant information should be included at the time of ordering.

Code numbers

	Size		Type	Code number
	mm	in.		
	250	10	SVA-DL 250 D CAP	148B3760
	250	10	SVA-DL 250 D H-HEEL	148B3761
	250	10	SVA-DL 250 A CAP	148B3762
	250	10	SVA-DL 250 A H-WHEEL	148B3763
	250	10	SVA-DH 250 D CAP	148B3764
	250	10	SVA-DH 250 D H-WHEEL	148B3765
	250	10	SVA-DH 250 A CAP	148B3766
	250	10	SVA-DH 250 A H-WHEEL	148B3767
	300	12	SVA-DL 300 D CAP	148B3770
	300	12	SVA-DL 300 D H-WHEEL	148B3771
	300	12	SVA-DL 300 A CAP	148B3772
	300	12	SVA-DL 300 A H-WHEEL	148B3773
	300	12	SVA-DH 300 D CAP	148B3774
	300	12	SVA-DH 300 D H-WHEEL	148B3775
	300	12	SVA-DH 300 A CAP	148B3776
	300	12	SVA-DH 300 A H-WHEEL	148B3777

A = ANSI butt-weld
D = DIN butt-weld

H-WHEEL: Handwheel
CAP: Vented cap

